

Eminere[®] Remote MC 1
Eminere[®] Remote MC 2
Eminere[®] Remote MC 3
Eminere[®] Remote MC 4

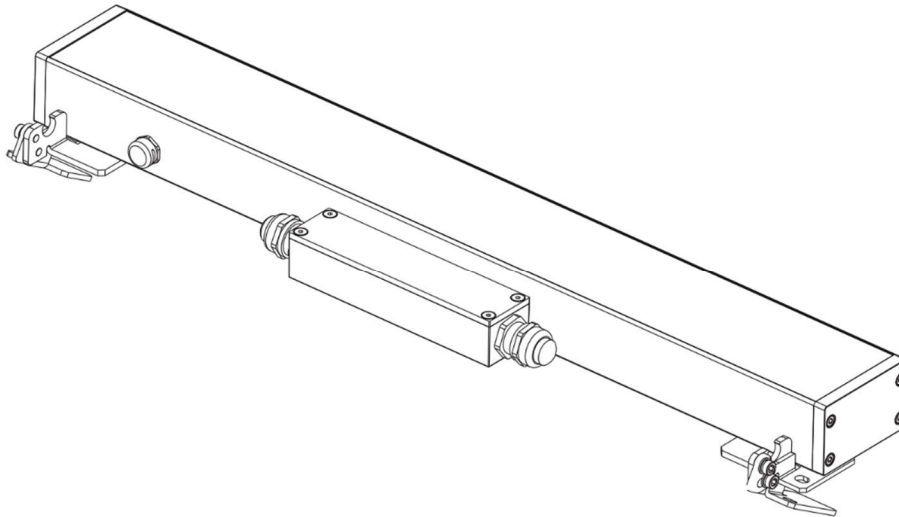

QR code for user manual



Table of contents

1. Safety instructions	3
2. Fixture exterior view	5
3. Installation	5
3.1 Mounting the fixture	5
3.2 Connection to driver	5
3.3 Wiring of the junction box	8
3.4 Example of Control panel in RDM manager	11
4. Software update	12
5. Technical specifications	13
6. Cleaning and maintenance	15
6.1 Disposing of the product	15
7. ChangeLog	15

**FOR YOUR OWN SAFETY, PLEASE READ THIS USER MANUAL CAREFULLY
BEFORE POWERING OR INSTALLING YOUR Eminere Remote MC !
Save it for future reference.**

This device has left our premises in absolutely perfect condition. In order to maintain this condition and to ensure safe operation, it is absolutely necessary for the user to follow the safety instructions and warnings written in this manual.

The manufacturer will not accept liability for any resulting damages caused by the non-observance of this manual or any unauthorized modification to the device.

Unauthorized modification will void warranty.

1. Safety instructions

DANGEROUS VOLTAGE CONSTITUTING A RISK OF ELECTRIC SHOCK IS PRESENT WITHIN THIS UNIT!

Always disconnect the fixture from power before cleaning, servicing or installing.

This fixture falls under protection class III.

LED light emission. Risk of eye injury. Do not look into the beam from a short distance without suitable protective eyewear. Do not look at LEDs with magnifiers or similar optical instruments that may concentrate the light output.

The fixture was designed for outdoor use. This fixture must not be used for underwater installation.

When choosing the installation spot, please make sure that the fixture is not exposed to extreme heat or dust. Do not install the unit near an open flame.

Avoid using the unit in locations subject to possible impacts.

The fixture body never must be covered with cloth or other materials when the fixture is under operation.

Only operate the fixture after having checked that the housing is firmly closed and all screws are tightly fastened.

The fixture becomes hot during operation. Allow the fixture to cool approximately 30 minutes prior to servicing or maintenance.

Operate the fixture only after having familiarized yourself with its functions. Do not permit operation by persons not qualified to operate the fixture.

Please consider that unauthorized modifications on the fixture are forbidden due to safety reasons!

Please use the original packaging if the fixture is to be transported.

If this device will be operated in any way different to the one described in this manual, the product may suffer damages and the warranty becomes void. Furthermore, any other operation may lead to dangers like short-circuit, burns, electric shock etc.

Refer servicing to qualified service personnel.

The product (covers and cables) must not be exposed to a high frequency electromagnetic field higher than 3V/m.

Immunity of the equipment is designed according to the standard EN 55035 Electromagnetic compatibility of multimedia equipment - Immunity requirements

Emission of the equipment complies with the standard EN55032 Electromagnetic compatibility of multimedia equipment – Emission Requirements according to class B.

This device complies with part 15 of the FCC Rules. Operation is subject to the following two conditions: (1) This device may not cause harmful interference, and (2) this device must accept any interference received, including interference that may cause undesired operation.

Changes or modifications not expressly approved by the party responsible for compliance could void the user's authority to operate the equipment.

The [Device] wireless operation is safe and complies to RF Exposure requirements.

This equipment has been tested and found to comply with the limits for a Class B digital device, pursuant to part 15 of the FCC Rules. These limits are designed to provide reasonable protection against harmful interference in a residential installation. This equipment generates, uses and can radiate radio frequency energy and, if not installed and used in accordance with the instructions, may cause harmful interference to radio communications. However, there is no guarantee that interference will not occur in a particular installation. If this equipment does cause harmful interference to radio or television reception, which can be determined by turning the equipment off and on, the user is encouraged to try to correct the interference by one or more of the following measures:

- Reorient or relocate the receiving antenna.
- Increase the separation between the equipment and receiver.
- Connect the equipment into an outlet on a circuit different from that to which the receiver is connected.
- Consult the dealer or an experienced radio/TV technician for help.

Warning for fixtures with Harsh Environment Finish (HEF):

Handle with care!

Avoid any damage to the painted surface.

Damaging the paint may result in corrosion and loss of warranty.

2. Fixture exterior view

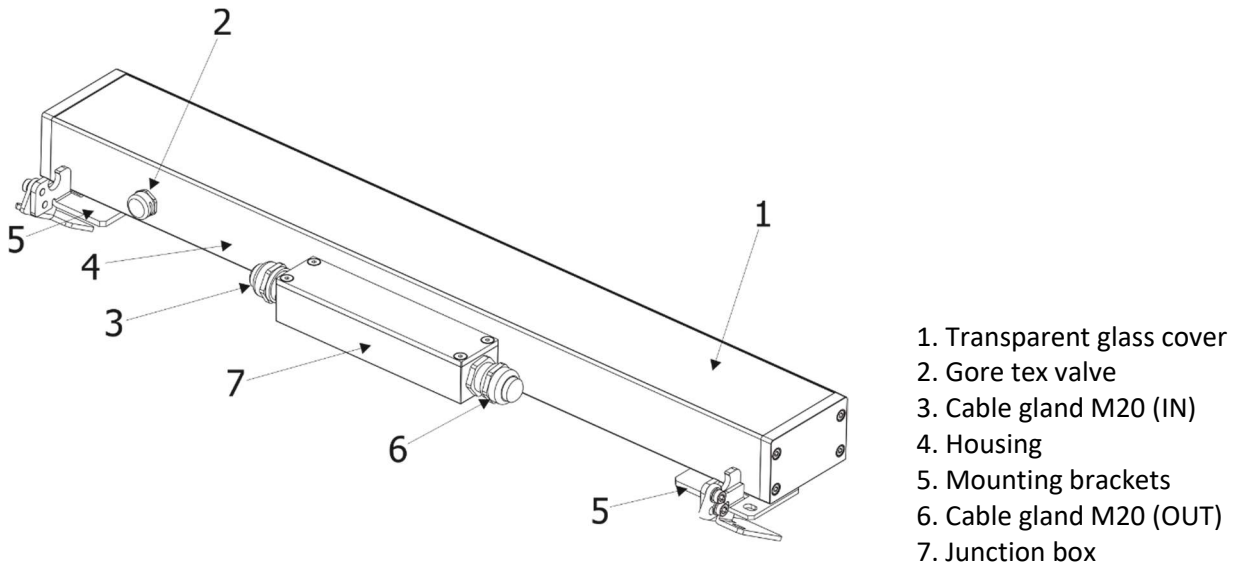

3. Installation

3.1 Mounting the fixture

The Eminere Remote MC can be arranged in any orientation on a flat, non-flammable surface by means of two mounting brackets (5) which can be tilted by 30°.

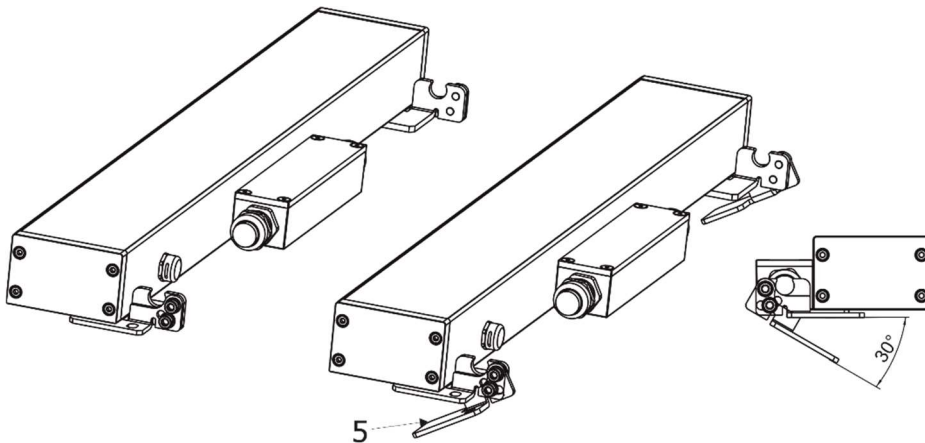

3.2 Connection to driver

The unit must be installed by a qualified electrician in accordance with all national and local electrical and construction codes and regulations.

The Eminere Remote MC modules should be connected to the E-Box Remote or E-Box Remote basic as stated in the chapter "Technical specifications".

Eminere Remote MC

Example of connection

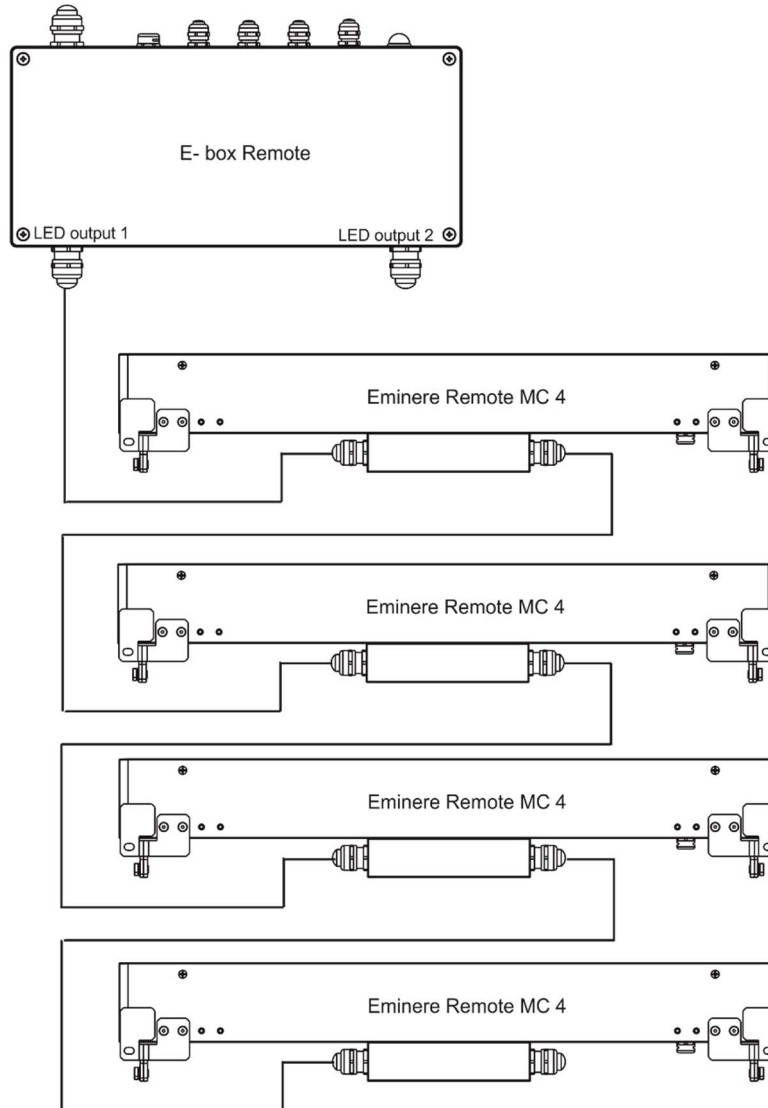

The table below states max. number of Eminere Remote MC modules connected to the E-box Remote/E-box Remote Basic.

Cable length *	Max. number of Emineres Remote MC connected to the E-box Remote/E-box Remote Basic			
	Eminere Remote MC 1	Eminere Remote MC 2	Eminere Remote MC 3	Eminere Remote MC 4
25 m	20	10	6	5
50 m	16	8	5	4
75 m	13	6	4	3
100 m	10	5	3	2

* Cable length is a total cable length between E-box Remote (E-box Remote Basic) and last connected Eminere Remote MC.

Example: Total cable length=L1+L2+L3+L4

Eminere Remote MC

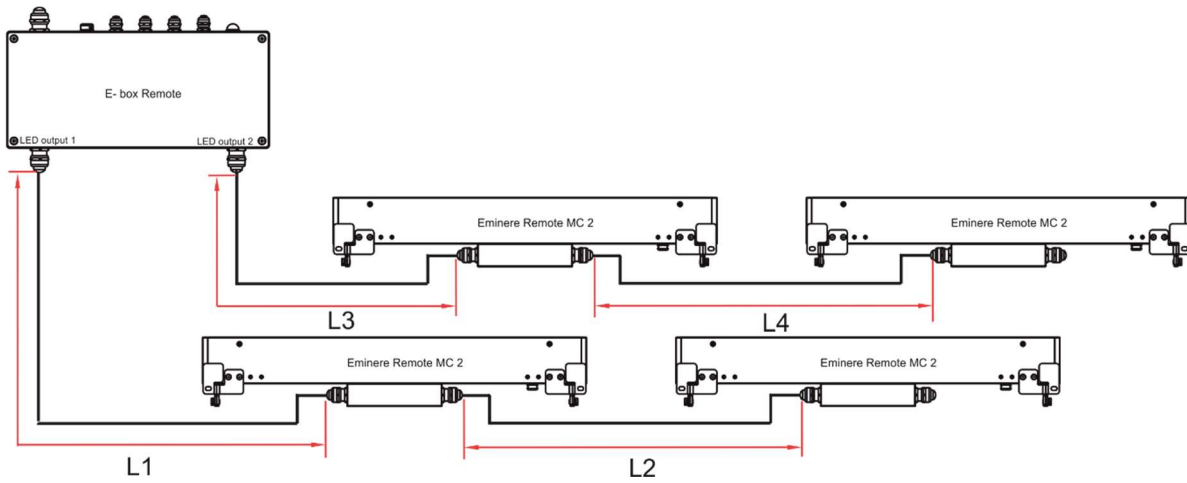

Max. number of Eminere Remote MC modules connected to the one output of the E-box Remote/E-box Remote Basic is stated in the following table.

Max. number of Emineres Remote MC connected to the one output of the E-box Remote/E-box Remote Basic			
Eminere Remote MC 1	Eminere Remote MC 2	Eminere Remote MC 3	Eminere Remote MC 4
16	8	5	4

Example: if you want to connect 20 Emineres Remote MC 1 to the E-box Remote, you may connect 16 Emineres Remote MC 1 to output 1 and 4 Emineres Remote MC 1 to output 2 (at total cable length of 25 m).

3.3 Wiring of the junction box

1. Unscrew the four screws (9) on the cover (8) of the junction box (7), remove the cover (8) and the gasket (10).
2. Remove the end cap (11) from cable glands before passing cables through cable glands M20 (3,6).
The cable glands M20x1.5 can be used for cables of a diameter of 7-13mm.
3. Pass the power/data cables through the cable glands (3,6) and connect them to the connection blocks (12, 13).
4. After checking all connections, fill the junction box with synthetic resin. Make sure that the End cap is inserted in unused cable gland before filling it.
At filling of the junction box proceed according instructions stated on the bag of the resin.
The connection blocks have to be fully poured in the resin.
5. Place the gasket (10) on the junction box (7) and screw the cover (8) to the junction box (7).
Check that all cable glands (and blind flange) and screws are firmly tightened.

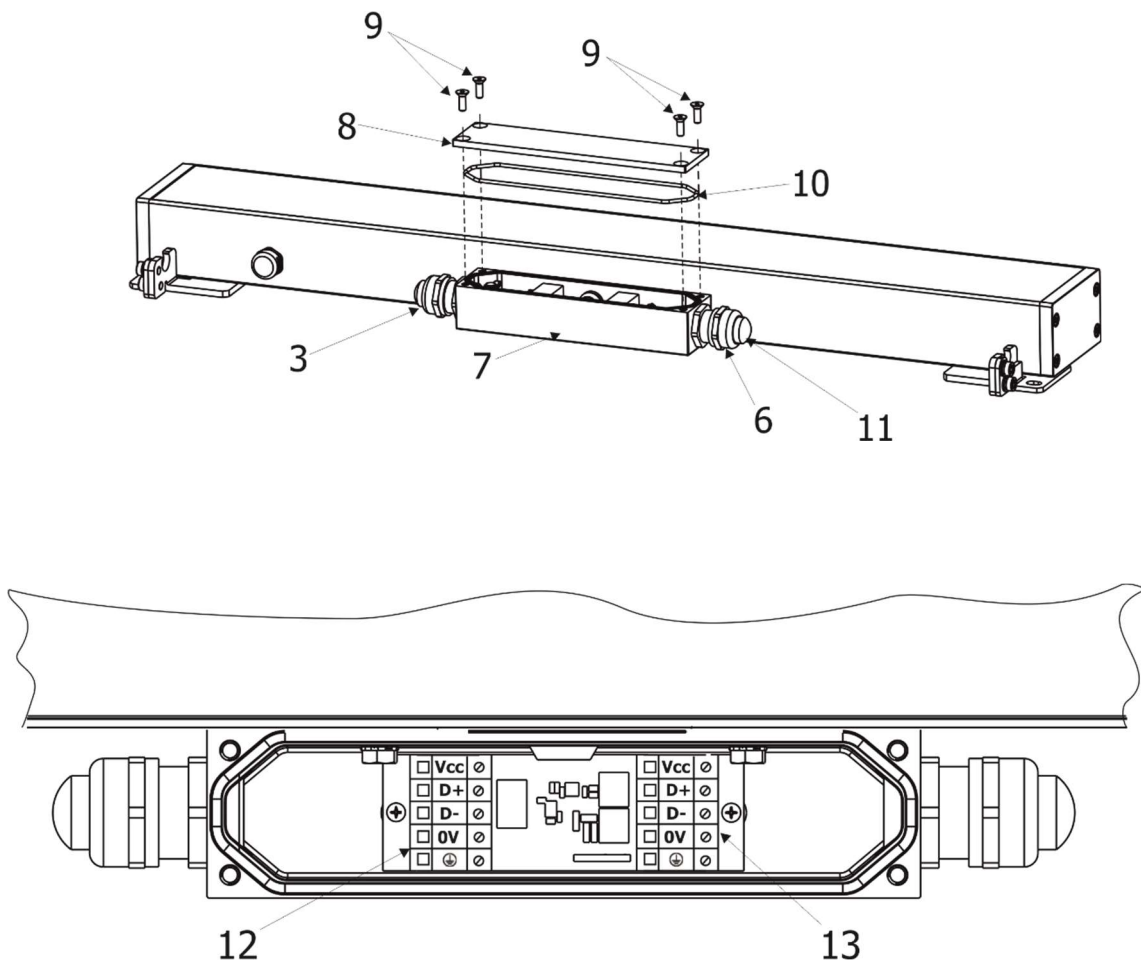

Wiring of connection blocks (12,13) in the junction box.

CE version

Connector	Vcc	D+	D-	0V	⊕
Function	LEDs +	Data +	Data -	LEDs -	Ground
Colour of wire	Red	Orange	White	Black	Not connected

US version

Eminere Remote MC

Connector	Vcc	D+	D-	0V	⊥
Function	LEDs +	Data +	Data -	LEDs -	Ground
Colour of wire	Red	Orange	White	Black	Yellow/Green

NOTE: Each line of Emineres Remote MC connected to the LED output of the E-box Remote/E-box Remote Basic has to be terminated at the last fixture.

EITHER connect a 120 Ohm resistor between terminals D+ and D- in the last fixture, **OR** terminate via RDM as described in the user manual for the E-box Remote.

Ensure **ONLY** the last fixture in the line is terminated using **ONE** of the above methods!

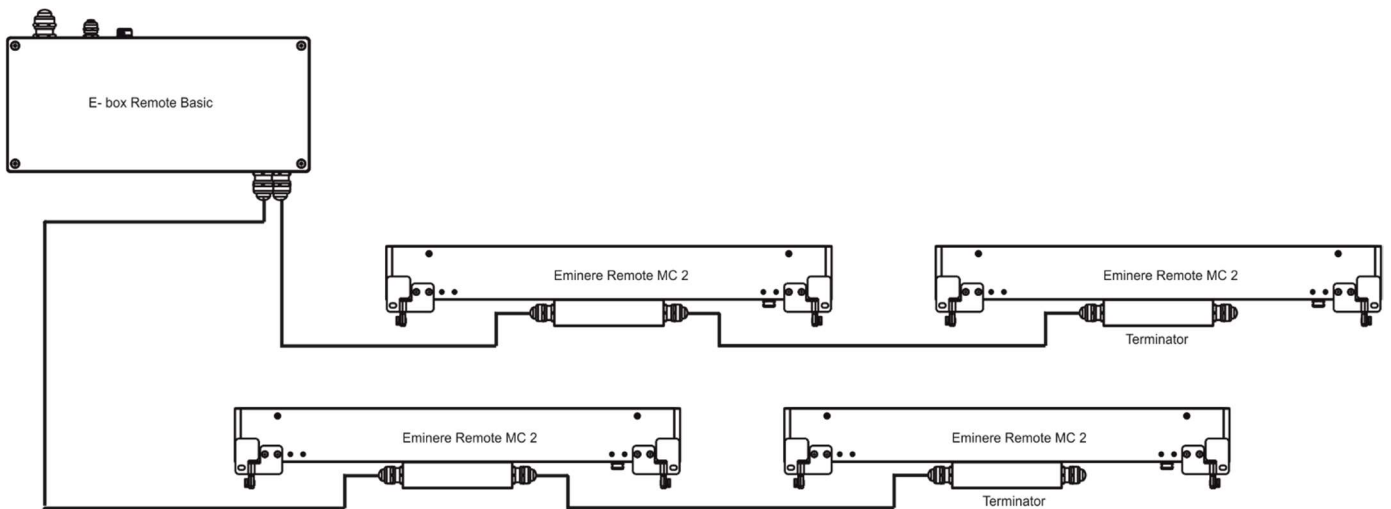
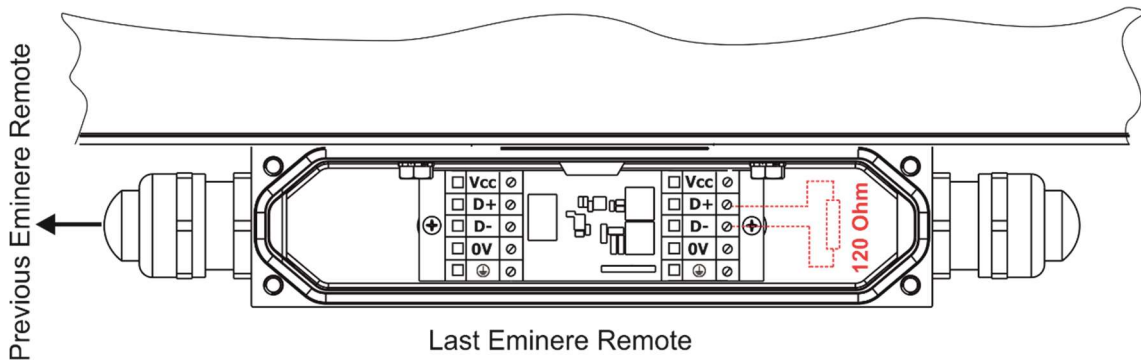

To keep declared IP rating of the fixture, every cable gland has to be covered with the end cap (11) if the cable gland is not used for cable passing.

We recommend to apply an adequate layer of the paste LOCTITE 5331 on the plastic holder of the cable gland before inserting it into the body of the gland and an adequate layer of the paste LOCTITE 577 on the thread of the body of gland (if the cable gland was screwed out).

Eminere Remote MC

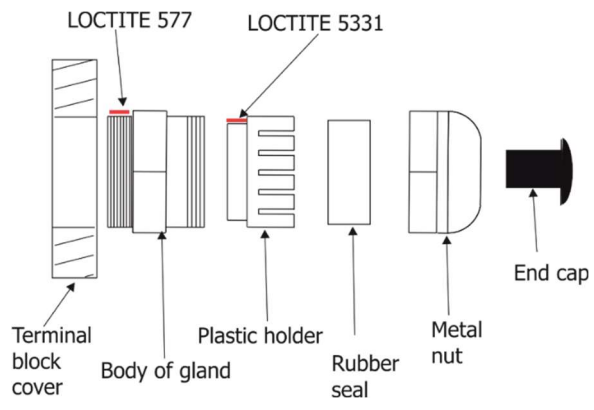

3.4 Example of Control panel in RDM manager

The software RDM manager is available on the ROBE website (<https://www.robe.cz/support>), product RUNIT WTX.

Control panel

Device: 52:53-01:2e:00:7f ▶

Product information

RDM protocol version: 0x0100

Device model ID: 0x010a

Product category: 0x0102

Software version: 18

Subdevice count: 0

Sensor count: 2

Manufacturer label: ROBE lighting s.r.o.

Device model description: Eminere

Device label:

DMX512 setup

DMX512 footprint: 12

Current personality:

Personalities count: 23

DMX address:

Power/Lamp setup

Device hours: 0

Configuration

Factory defaults:

Control

Identify device:

Display settings

Manufacturer PIDs

Wireless Unlink 1-unlink: (hex)

LED calibration 4byte HEX! (RGBW/RGBA): (hex)

Insect friendly light (0 = off, 1 = on): (hex)

Pixel swap (0-dis 1-act): (hex)

Terminator active (0-dis 1-en): (hex)

Green arrow ▶ saves changes made in the Control panel to the Eminere Remote MC.

Manufacturer PIDs

Wireless unlink - the item is not active for the Eminere Remote MC.

LED calibration 4byte HEX! (RGBW/RGBA) - the item shows 4 bytes of calibration values for calibrated white colours of RGBW(RGBA) Eminere Remote MC.

E.g.



CTC channel has to be set to some calibrated white colour (21 DMX-1800K, 66 DMX-2700K, 91 DMX-3200K, 141 DMX-4200K, 211 DMX-5600K, 255 DMX-6500K) otherwise the item shows values "ff ff ff ff" (and calibration values cannot be saved to the Eminere Remote MC).

Warning!

Changing and saving values in this item will effect calibrated white colour(s) of the Eminere Remote MC .

Insect friendly light - the item effects RGBA Eminere Remote MC only. If the item is on, blue colour is not used in calibrated white colours. This modification of white lights results in a smaller attraction of white light for insects (mosquitos, moths..). The function is also available from DMX chart (channel Special Function, range 7-10 DMX).

Pixel Swap – the item allows you to swap the pixel order (for Eminere Remote MC 2/3/4 only).

Terminator active - the item allows you to terminate line of Emineres Remote MC at last Eminere Remote MC.

4. Software update

Software update of Eminere Remote MC has to be done by means of the software ROBE Uploader running on PC. The ROBE Uploader is a software for automatized software update of ROBE fixtures. The ROBE Uploader switches Emineres Remote MC to the update mode automatically.

Please see <https://www.robe.cz/robe-uploader/> for more information about ROBE uploader and the E-box Remote user manual (E-box Remote Basic user manual).

5. Technical specifications

Power supply

- Input voltage: 48 V
- Power consumption:
 - Eminere Remote MC 1: 20W
 - Eminere Remote MC 2: 40W
 - Eminere Remote MC 3: 60W
 - Eminere Remote MC 4: 80W

Optic

- Light source:
 - Eminere Remote MC 1: 4 x high power multi chip LEDs
 - Eminere Remote MC 2: 8 x high power multi chip LEDs
 - Eminere Remote MC 3: 12 x high power multi chip LEDs
 - Eminere Remote MC 4: 16 x high power multi chip LEDs
- Colour variants: RGBW (W - 6500 K), RGBA, PW (W - 3000 K)
- Beam angles: Symetrical: 12°, 15°, 25°, 30°, 45°, 65°, 100°
Bi-symetrical: 10° x 30°, 30° x 10°, 10° x 60°, 60° x 10° 15° x 45°, 45° x 15°, 15° x 90°, 90° x 15°
- Projected Lumen Maintenance: L90B10 >90.000 hrs, Ta = 25°C / 77°F

Compatible drivers

- E-box Remote, E-box Remote Basic

Mounting method

- Via two L-shape brackets with adjustment range 30°

Housing

- Aluminium extruded body
- Tempered glass

Cooling system

- Convection

Total heat dissipation

- Eminere Remote MC 1: 51 BTU/h (calculated)
- Eminere Remote MC 2: 102 BTU/h (calculated)
- Eminere Remote MC 3: 154 BTU/h (calculated)
- Eminere Remote MC 4: 205 BTU/h (calculated)

Weight

- Eminere Remote MC 1: 2.2 kg (4.85 lbs)
- Eminere Remote MC 2: 3.3 kg (7.3 lbs)
- Eminere Remote MC 3: 4.3 kg (9.5 lbs)
- Eminere Remote MC 4: 5.3 kg (11.7 lbs)

Eminere Remote MC

Dimensions (All dimensions in mm [inch])

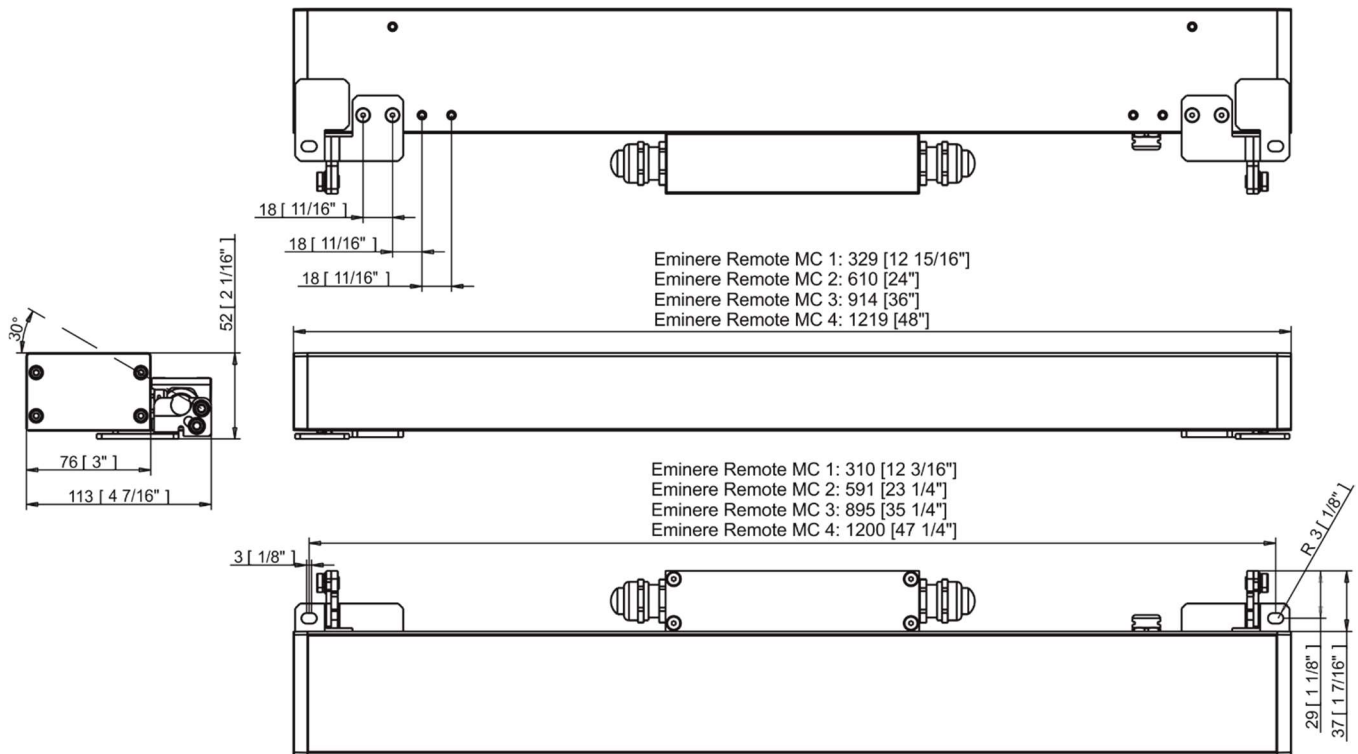

Protection factor

- CE: IP 67
- US: Suitable for wet location

Impact rating

- CE: IK06

Operating ambient temperature range

- -20°C /+40°C (-4°F /+104°F)

Operating temperature

- +67°C @ Ambient +40°C (+153°F @ Ambient +104°F)

Connection

- 5-cored cable

Included items

- 1 x Eminere Remote MC
- 1 x User manual

Optional accessories

- Mounting Bracket 50 RAL 9011 (P/N 10980521)
- Mounting Bracket 100 RAL 9011 (P/N 10980522)
- Mounting Bracket 200 RAL 9011 (P/N 10980523)
- Mounting Bracket 200 RAL 9006 (P/N 10980663)
- Mounting Bracket 300 RAL 9011 (P/N 10980524)
- Mounting Bracket- Custom length
- Cable for Eminere Remote (P/N 13053336)

6. Cleaning and maintenance

DANGER !
Disconnect from the mains before starting any maintenance or cleaning work

Rinse off loose dirt with low pressure water spray. Wash the housing with a soft brush or sponge and a mild, non-abrasive washing detergent. Rinse it.

Maintenance and service operations are only to be carried out by a qualified person.

Should you need any spare parts, please use ROBE OEM parts.

6.1 Disposing of the product

To preserve the environment please dispose or recycle this product at the end of its life according to the local regulations and codes.

7. ChangeLog

This section summarizes changes in the user manual.

Version of the manual	Date of issue	Description of changes
1.1	11/01/2024	Description of junction box connection changed
1.2	31/01/2024	Control panel of RDM manager added, DMX chart ver. 3.3
1.3	16/02/2024	Notice about Protection class III added to Safety instructins

Specifications are subject to change without notice.

February 16, 2024

Copyright © 2020-2024 Robe Lighting - All rights reserved

Made in CZECH REPUBLIC by ROBE LIGHTING s.r.o. Palackeho 416/20 CZ 75701 Valasske Mezirici

**DMX protocol for: Eminere 1/2/3/4; Eminere Side 1/2/3/4;
Eminere Inground 2/4; Eminere Remote 1/2/3/4;
UVinere 2/4; UVinere Remote 1/2/4**

Version: 3.3 (23 modes in total), software version 3.0 and higher

Mode/Channels in all								Mode 1: RGBW(A)-8bit, Mode 2: RGB 8-bit, Mode 3: full RGBW(A)	
1	2	3	4	5	6	7	8-10	Mode 4: White-full control, Mode 5: Reduced RGBW(A)	
4	3	12	3	6	8	15	Reserved	Mode 6- Reduced RGBW(A)+white control	
								Mode 7- full RGBW(A)+virtual colour wheel	
								RGBW(A) / RGB modes	
Mode/channels							DMX Value	Function	Type of control
1	2	3	4	5	6	7			
-	-	-	-	-	-	1	0	Special functions No function	step
								<i>To activate following functions , stop in DMX value for at least 3 sec.</i>	
							1-2	Save current DMX values to fixture as initial DMX values.	step
							3-4	Show saved initial DMX values	step
							5-6	Run factory demo sequences at switching fixture on (without DMX)	step
							7-8	Insect friendly light On (RGBA version only)	step
							9-10	Insect friendly light Off (RGBA version only)	step
							11-255	Reserved	
1	1	1	-	1	1	2	0-255	Red Red LEDs saturation control (0-100%)	proportional
-	-	2	-	-	-	3	0-255	Red Fine Red LEDs saturation control fine	proportional
2	2	3	-	2	2	4	0-255	Green Green LEDs saturation control (0-100%)	proportional
-	-	4	-	-	-	5	0-255	Green Fine Green LEDs saturation control fine	proportional
3	3	5	-	3	3	6	0-255	Blue Blue LEDs saturation control (0-100%)	proportional
-	-	6	-	-	-	7	0-255	Blue Fine Blue LEDs saturation control fine	proportional
4	-	7	-	4	4	8	0-255	White (Amber) White LEDs saturation control (0-100%)	proportional
-	-	8	-	-	-	9	0-255	White (Amber) Fine White LEDs saturation control fine	proportional
-	-	9	1	-	5	10	0	Green correction Uncorrected white	step
							1-127	Minus green --> uncorrected white	proportional
							128	Uncorrected white (128=default)	step
							129-255	Uncorrected white --> Plus green	proportional
-	-	10	2	-	6	11	0	Colour temperature correction (CTC) No function	step
							1-10	Tungsten dimming 2700 K	step
							11-20	Tungsten dimming 3200 K	step
							21-255	Colour temperature changing from 1800 K --> 6500 K	proportional

DMX protocol

Mode/channels							DMX Value	Function	Type of control
1	2	3	4	5	6	7			
								(21-1800K, 66-2700K, 91-3200K,141-4200K, 211-5600K, 255-6500K)	
-	-	-	-	-	-	12		Virtual Colour Wheel	
							0	No function	step
							1-2	White 1800 K	step
							3-4	White 2700 K	step
							5-6	White 3200 K	step
							7-8	White 4200 K	step
							9-10	White 5600 K	step
							11-12	White 6500 K	step
							13	Blue (Blue=full, Red+Green+White/Amber=0)	step
							14-23	Red=0, Green->up,Blue =full, White/Amber=0	proportional
							24	Cyan (Red=0, Green=full, Blue =full, White/Amber=0)	step
							25-34	Red=0, Green=full, Blue->down, White/Amber=0	proportional
							35	Green (Red=0, Green=full, Blue =0, White/Amber=0)	step
							36-45	Red->up, Green=full, Blue=0, White/Amber=0	proportional
							46	Yellow (Red=full, Green=full, Blue=0, White/Amber=0)	step
							47-56	Red=full, Green->down, Blue=0, White/Amber=0	proportional
							57	Red(Red=full, Green=0, Blue=0, White/Amber=0)	step
							58-67	Red=full, Green=0, Blue->up, White/Amber=0	proportional
							68	Magenta (Red=full, Green=0, Blue=full, White/Amber=0)	step
							69-78	Red -> down, Green=0, Blue=full, White/Amber=0	proportional
							79	Blue (Red=0, Green=0, Blue=full, White/Amber=0)	step
								Transition effects	
							80-87	Rainbow effect (with fade time) from slow-> fast	proportional
							88-95	Rainbow effect (without fade time) from slow-> fast	proportional
							96-103	Full dynamic white (1800K->6500K->1800K) (with fade time) from slow-> fast	proportional
							104-111	Full dynamic white (1800K->6500K->1800K) (without fade time) from slow-> fast	proportional
							112-119	Dynamic warm white (1800K-3000K-1800K) (with fade time) from slow-> fast	proportional
							120-127	Dynamic warm white (1800K-3000K-1800K) (without fade time) from slow-> fast	proportional
							128-135	Rainbow effect + full dynamic white (with fade time) from slow-> fast	proportional
							136-143	Rainbow effect + full dynamic white (without fade time) from slow-> fast	proportional
							144-151	Blue/Green effect (with fade time) from slow-> fast	proportional
							152-159	Blue/Green effect (without fade time) from slow-> fast	proportional
							160-167	Red/Blue effect (with fade time) from slow-> fast	proportional
							168-175	Red/Blue effect (without fade time) from slow-> fast	proportional
							176-183	Green/Red effect (with fade time) from slow-> fast	proportional
							184-191	Green/Red effect (without fade time) from slow-> fast	proportional
							192-199	Blue/4000K effect (with fade time) from slow-> fast	proportional
							200-207	Blue/4000K effect (without fade time) from slow-> fast	proportional
							208-215	Green/4000K effect (with fade time) from slow-> fast	proportional
							216-223	Green/4000K effect (without fade time) from slow-> fast	proportional
							224-231	Red/4000K effect (with fade time) from slow-> fast	proportional
							232-239	Red/4000K effect (without fade time) from slow-> fast	proportional
							240-255	Reserved	

DMX protocol

Mode/channels							DMX Value	Function	Type of control
1	2	3	4	5	6	7			
						13		Shutter/Strobe	
							0-31	Shutter closed	step
							32-63	Shutter open	step
							64-95	Strobe-effect from slow to fast	proportional
							96-127	Shutter open	step
							128-143	Opening pulse in sequences from slow to fast	proportional
							144-159	Closing pulse in sequences from fast to slow	proportional
							160-191	Shutter open	step
							192-223	Random strobe-effect from slow to fast	proportional
							224-255	Shutter open	step
-	-	11	3	5	7	14		Dimmer	
							0-255	Light intensity coarse (0-100%)	proportional
-	-	12	-	6	8	15		Dimmer Fine	
							0-255	Light intensity fine	proportional
Copyright © 2022-2024 Robe Lighting s.r.o. - All rights reserved									
All Specifications subject to change without notice									

DMX protocol for: Eminere 1/2/3/4; Eminere Side 1/2/3/4; Eminere Inground 2/4; Eminere Remote 1/2/3/4; UVinere 2/4; UVinere Remote 1/2/4					
Version: 3.3 (23 modes in total)					
Mode/Channels in all				Mode 11: White selection, Mode 12: WW + CW	
11	12	13	14-16	Mode 13: Only dimmer	
3	4	2	Reserved	<i>Mode 13 is suitable for UVinere and UVinere Remote</i>	
TW and PW modes					
Mode/channels			DMX Value	Function	Type of control
11	12	13			
1	-	-	0 - 255	White colour selection White from 2700 K - 6500 K	proportional
-	1	-	0 - 255	Warm White Warm White LEDs saturation control (0-100%)	proportional
-	2	-	0 - 255	Cool White Cool White LEDs saturation control (0-100%)	proportional
2	3	1	0 - 255	Dimmer Light intensity coarse (0 - 100%)	proportional
3	4	2	0 - 255	Dimmer Fine Light intensity fine	proportional
Copyright © 2022-2024 Robe Lighting s.r.o. - All rights reserved					
All Specifications subject to change without notice					

**DMX protocol for: Eminere 1/2/3/4; Eminere Side 1/2/3/4;
Eminere Inground 2/4; Eminere Remote 1/2/3/4;**

Version: 3.3 (23 modes in total)

Mode/Channels in all					Mode 17: RGBW(A) pixels, Mode 18: RGB pixels, Mode 19: TW pixels, Mode 20: PW dimmer pixels		
17	18	19	20	21-23			
16	12	8	8	Reserved			
Mode/channels					DMX Value	Pixel modes	Type of control
17	18	19	20		Function		
1	1	-	-	0 - 255	Red 1 -Eminere 1/2/3/4 Red LEDs saturation control (0-100%)	proportional	
2	2	-	-	0 - 255	Green 1-Eminere 1/2/3/4 Green LEDs saturation control (0-100%)	proportional	
3	3	-	-	0 - 255	Blue 1-Eminere 1/2/3/4 Blue LEDs saturation control (0-100%)	proportional	
4	-	-	-	0 - 255	White (Amber) 1-Eminere 1/2/3/4 White LEDs saturation control (0-100%)	proportional	
5	4	-	-	0 - 255	Red 2 -Eminere 2/3/4 Red LEDs saturation control (0-100%)	proportional	
6	5	-	-	0 - 255	Green 2-Eminere 2/3/4 Green LEDs saturation control (0-100%)	proportional	
7	6	-	-	0 - 255	Blue 2-Eminere 2/3/4 Red LEDs saturation control (0-100%)	proportional	
8	-	-	-	0 - 255	White (Amber) 2-Eminere 2/3/4 White LEDs saturation control (0-100%)	proportional	
9	7	-	-	0 - 255	Red 3-Eminere 3/4 Red LEDs saturation control (0-100%)	proportional	
10	8	-	-	0 - 255	Green 3-Eminere 3/4 Green LEDs saturation control (0-100%)	proportional	
11	9	-	-	0 - 255	Blue 3-Eminere 3/4 Blue LEDs saturation control (0-100%)	proportional	
12	-	-	-	0 - 255	White (Amber) 3-Eminere 3/4 White LEDs saturation control (0-100%)	proportional	
13	10	-	-	0 - 255	Red 4-Eminere 4 Red LEDs saturation control (0-100%)	proportional	
14	11	-	-	0 - 255	Green 4-Eminere 4 Green LEDs saturation control (0-100%)	proportional	
15	12	-	-	0 - 255	Blue 4-Eminere 4 Blue LEDs saturation control (0-100%)	proportional	
16	-	-	-	0 - 255	White (Amber) 4 -Eminere 4 White LEDs saturation control (0-100%)	proportional	
-	-	1	-		Warm White 1 -Eminere 1/2/3/4 Warm White LEDs saturation control (0-100%)	proportional	
-	-	2	-	0 - 255	Cool White 1-Eminere 1/2/3/4 Cool White LEDs saturation control (0-100%)	proportional	
-	-	3	-		Warm White 2-Eminere 2/3/4		

DMX protocol

Mode/channels				DMX Value	Function	Type of control
17	18	19	20			
				0 - 255	Warm White LEDs saturation control (0-100%)	proportional
-	-	4	-	0 - 255	Cool White 2-Eminere 2/3/4 Cool White LEDs saturation control (0-100%)	proportional
-	-	5	-	0 - 255	Warm White 3-Eminere 3/4 Warm White LEDs saturation control (0-100%)	proportional
-	-	6	-	0 - 255	Cool White 3-Eminere 3/4 Cool White LEDs saturation control (0-100%)	proportional
-	-	7	-	0 - 255	Warm White 4 -Eminere 4 Warm White LEDs saturation control (0-100%)	proportional
-	-	8	-	0 - 255	Cool White 4 -Eminere 4 Cool White LEDs saturation control (0-100%)	proportional
-	-	-	1	0 - 255	Dimmer 1 Light intensity coarse (0 - 100%)	proportional
-	-	-	2	0 - 255	Dimmer Fine 1 Light intensity fine	proportional
-	-	-	3	0 - 255	Dimmer 2 Light intensity coarse (0 - 100%)	proportional
-	-	-	4	0 - 255	Dimmer Fine 2 Light intensity fine	proportional
-	-	-	5	0 - 255	Dimmer 3 Light intensity coarse (0 - 100%)	proportional
-	-	-	6	0 - 255	Dimmer Fine 3 Light intensity fine	proportional
-	-	-	7	0 - 255	Dimmer 4 Light intensity coarse (0 - 100%)	proportional
-	-	-	8	0 - 255	Dimmer Fine 4 Light intensity fine	proportional
Copyright © 2022-2024 Robe Lighting s.r.o. - All rights reserved						
All Specifications subject to change without notice						