

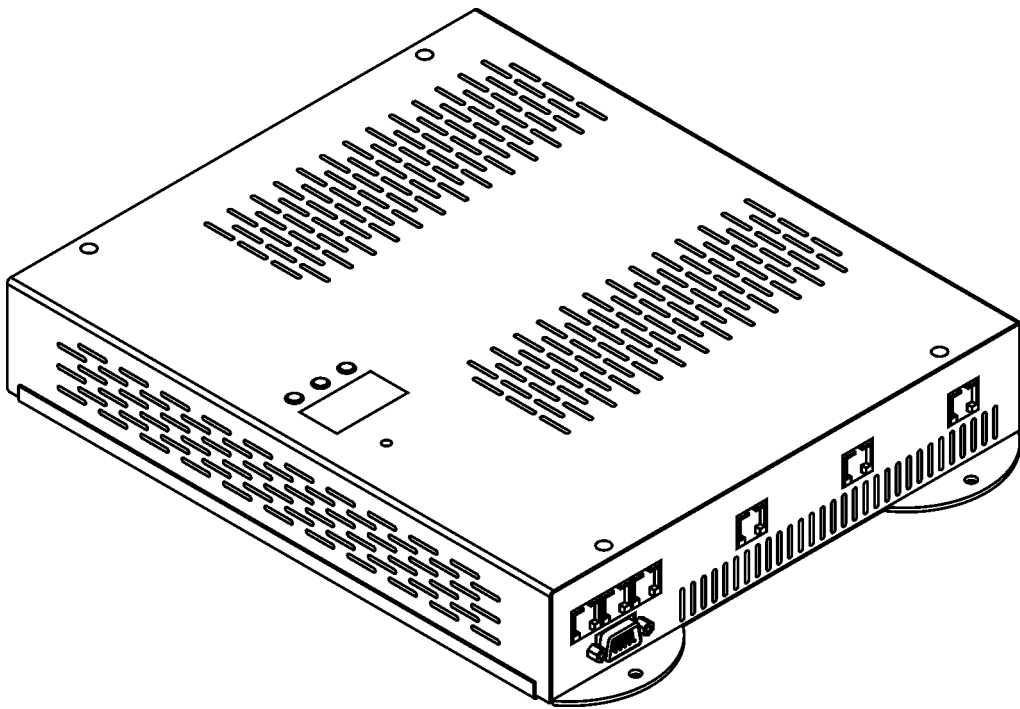

## ArcPower 144



## USER MANUAL

**Version: 2.6**  
CE



# ArcPower 144

## Table of contents

1. Safety instructions .....	4
2. Operating determinations .....	4
3. Description of the ArcPower 144 .....	4
4. Installation .....	5
4.1 Connection to the mains .....	5
4.2 Mounting the ArcPower 144 .....	6
4.3 Connection cables .....	7
5. Installing instruction .....	6
5.1 DMX operating .....	6
5.2 Master-slave operating .....	8
5.3 Operating via Dynet protocol .....	9
6. Control menu map .....	11
7. DMX protocol .....	12
8. Control board .....	13
8.1 Addressing the ArcPower 144 .....	13
8.2 Program running .....	14
8.3 Manual mode .....	15
8.4 Test sequences .....	15
8.5 Stand-alone mode .....	15
8.6 Special function .....	16
9. Control of the ArcPower 36 via RS-232.....	18
9.1 Wiring an RS-232 serial port.....	18
9.2 Selecting a zone.....	18
9.3 Setting a serial port of PC.....	18
9.4 Zone commands.....	18
10. Technical Specification .....	20
11. Replacing the fuse .....	21

**CAUTION!**  
**Unplug mains lead before opening the housing!**

**FOR YOUR OWN SAFETY, PLEASE READ THIS USER MANUAL CAREFULLY BEFORE YOU INITIAL START - UP!**

## 1. Safety instructions

Every person involved with installation and maintenance of this product has to:

- be qualified
- follow the instructions of this manual

**CAUTION!**  
**Be careful with your operations. With a high voltage you can suffer a dangerous electric shock when touching the wires inside the unit!**

This product has left our premises in absolutely perfect condition. In order to maintain this condition and to ensure a safe operation, it is absolutely necessary for the user to follow the safety instructions and warning notes written in this manual.

**To prevent from danger of accident, the device has to be fixed on flat, non-flammable surface in compliance with the installing instruction included in this manual.**

### Important:

The manufacturer will not accept liability for any resulting damages caused by the non-observance of this manual or any unauthorized modification to the product.

Always ground the unit.

The electric connection, repairs and servicing must be carried out by a qualified employee.

Do not connect this unit to a dimmer pack.

Use a source of AC power that complies with local building and electrical rules.

AC power has to have both overload and short circuit protection

## 2. Operating determinations

This product was designed for indoor use only.

If the unit has been exposed to drastic temperature fluctuation (e.g. after transportation), do not switch it on immediately. The arising condensation water might damage your unit. Leave the unit switched off until it has reached room temperature.

Avoid brute force when installing or operating the unit.

When choosing the installation-spot, please make sure that the unit is not exposed to extreme heat, moisture or dust.

Only operate the unit after having checked that the housing is firmly closed and all screws are tightly fastened.

The maximum ambient temperature 40° C must never be exceeded.

Operate the unit only after having familiarized with its functions. Do not permit operation by persons not qualified for operating the unit. Most damages are the result of unprofessional operation!

Please use the original packaging if the product is to be transported.

Please consider that unauthorized modifications on the unit are forbidden due to safety reasons!

## 3. Description of the ArcPower 144

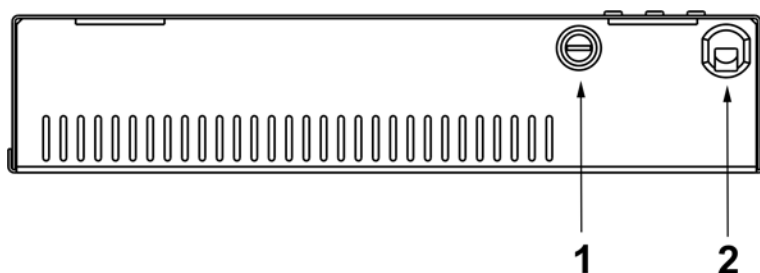

1 - Fuse Holder  
2 - Power Cord

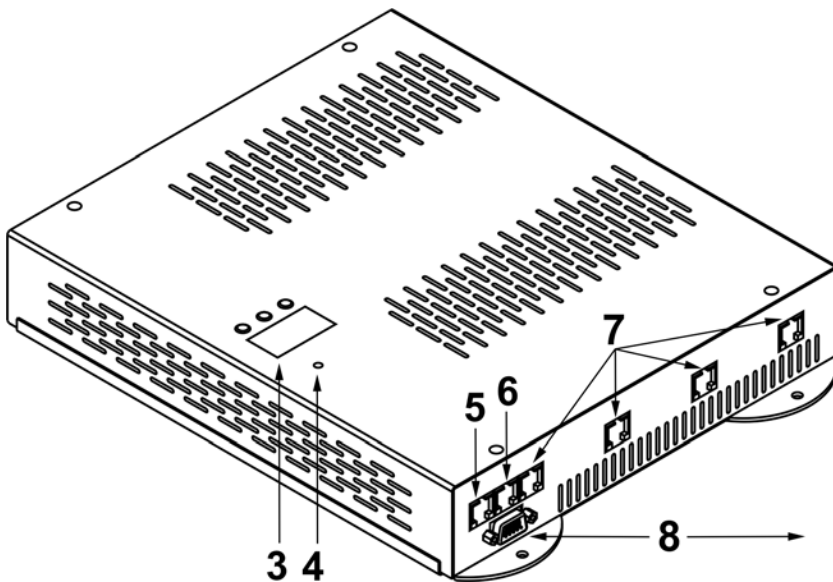

- 3 - Control Board
- 4 - Power Indicator
- 5 - DMX Output
- 6 - DMX Input
- 7 - LED Zone Outputs
- 8 - RS 232 Input

Front view of the socket:

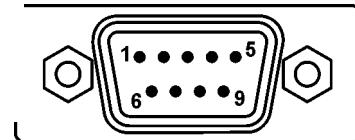

#### RS232 Input

Canon 9-pin male

**Pin 1:** Not connected

**Pin 2:** Received Data

**Pin 3:** Transmitted Data

**Pin 4:**

**Pin 5:** Signal Ground

**Pin 6:**

**Pin 7:**

**Pin 8:**

**Pin 9:** Not connected

RJ45 socket

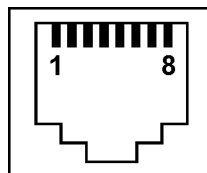

#### DMX Input

**Pin 1:** Not connected

**Pin 2:** +12V

**Pin 3:** Not connected

**Pin 4:** Not connected

**Pin 5:** Not connected

**Pin 6:** Data +

**Pin 7:** Data -

**Pin 8:** GND

#### DMX Output

**Pin 1:** Not connected

**Pin 2:** Not connected

**Pin 3:** Not connected

**Pin 4:** Not connected

**Pin 5:** Not connected

**Pin 6:** Data +

**Pin 7:** Data -

**Pin 8:** GND

#### LED module Input

**Pin 1:** Red LED +

**Pin 2:** Green LED +

**Pin 3:** Blue LED +

**Pin 4:** White LED +

**Pin 5:** Red LED -

**Pin 6:** Green LED -

**Pin 7:** Blue LED -

**Pin 8:** White LED -

## 4. Installation

### 4.1 Connection to the mains:

The ArcPower 144 is equipped with auto-switching power supply that automatically adjusts to any 50/60Hz AC power source from 100-240 Volts.

Carefully prepare the end of the the supply cord and fit a suitable plug. A 3-prong grounding-type plug must be installed following the manufacturer's instructions. The earth has to be connected!

Cord plug connections:

Cable	Pin	International
Brown	Live	L
Light blue	Neutral	N
Yellow/Green	Earth	

***This device falls under protection class I. Therefore the ArcPower 144 has to be connected to a mains socket outlet with a protective earthing connection.***

### 4.2. Mounting the ArcPower 144

The ArcPower 144 should be placed on a non-flammable flat surface in any orientation and fixed by the four screws. There are 4 mounting holes of 5x7 mm in housing of the driver.

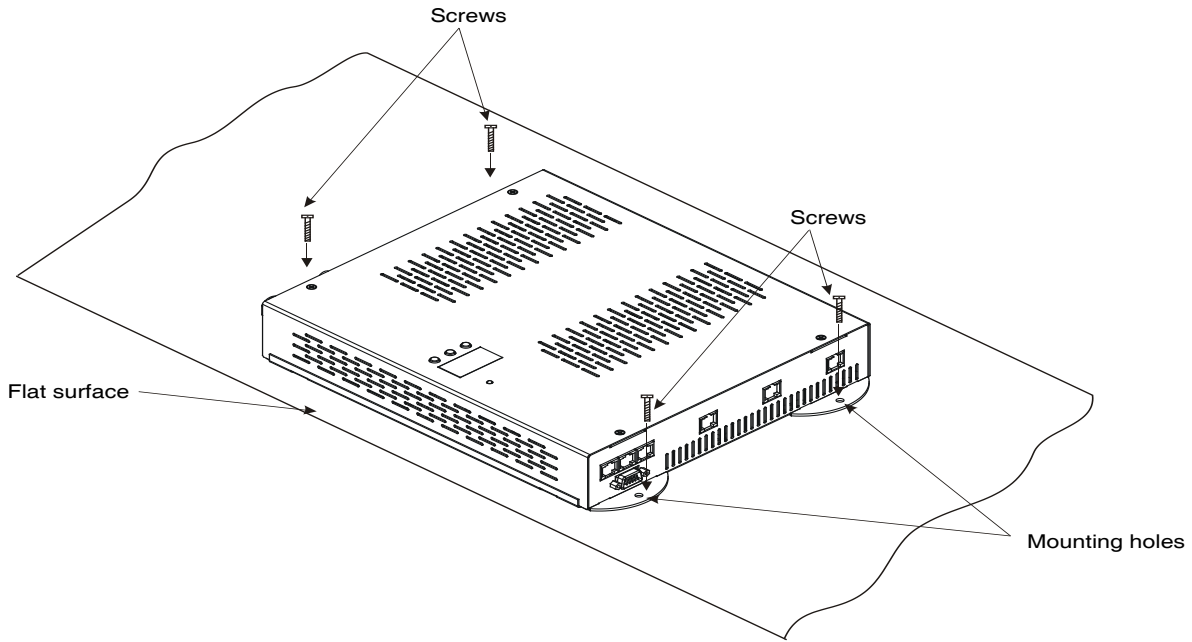

### 4.3 Connection cables

1. The adapter cable RJ45/XLR connects the ArcPower 144 to the DMX controller. If your DMX controller has RJ45 socket for DMX output, use RJ45 patch cable for connection with the ArcPower 144.

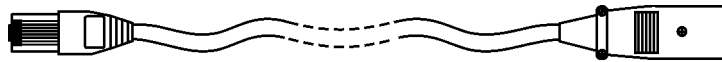

**RJ45 plug**  
View facing pins

**DMX 512 XLR plug (male)**  
Front view of the plug

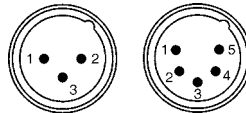

- Pin 1: Not used
- Pin 2: Not used
- Pin 3: Not used
- Pin 4: Not used
- Pin 5: Not used
- Pin 6: **Data +**
- Pin 7: **Data -**
- Pin 8: **GND**

- Pin 1: **GND**
- Pin 2: **Data -**
- Pin 3: **Data +**
- Pin 4: Not used
- Pin 5: Not used

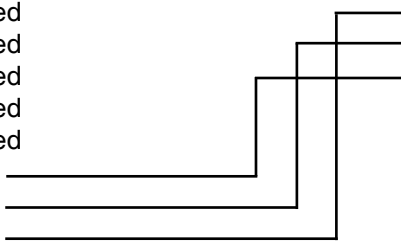

2. RJ45 patch cables category 5 that connect the ArcPower 144 each other are wired 1:1, that is, pins with the same numbers are connected together.

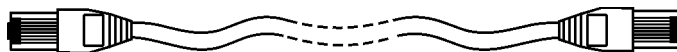

- Pin 1: Not used
- Pin 2: Not used
- Pin 3: Not used
- Pin 4: Not used
- Pin 5: Not used
- Pin 6: **Data +**
- Pin 7: **Data -**
- Pin 8: **GND**

- Pin 1: Not used
- Pin 2: Not used
- Pin 3: Not used
- Pin 4: Not used
- Pin 5: not used
- Pin 6: **Data +**
- Pin 7: **Data -**
- Pin 8: **GND**

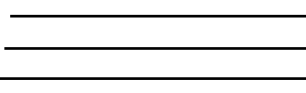

## 5. Installing instructions

### 5.1 DMX operating

1. Unplug from the mains before installation.
2. Connect the LED modules to the fixture.
3. Connect DMX controller to the fixture.
4. Connect the fixture to the mains.
5. Set the DMX address on the control board of the fixture (see chapter "Control board").

**Warning!** *Accidental connection DMX 512 Input/Output to non-DMX 512 device (e.g. Ethernet network Hub) can damage the ArcPower 144. Maximum total cable length between one LED zone output of the Arcpower 144 and all its connected LED modules is 80 metres.*

#### Single ArcPower 144 installation:

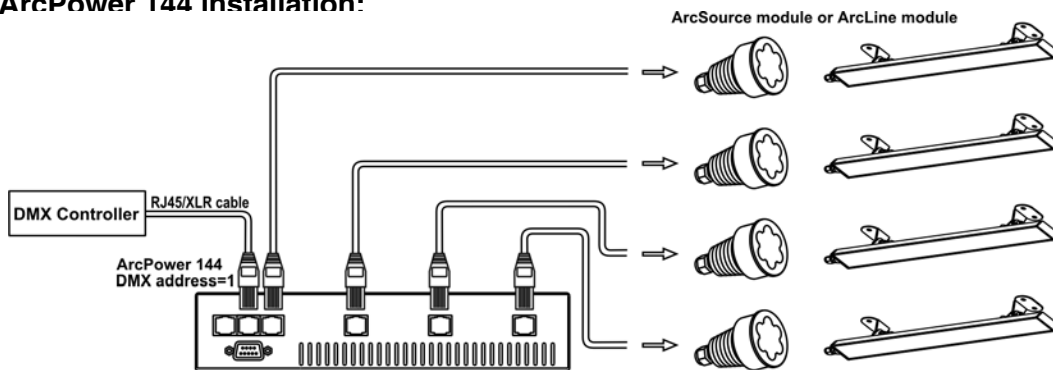

#### Multiple ArcPower 144 installation:

Connect the DMX output of the first ArcPower 144 with the DMX input of the next ArcPower 144. Always connect one output with the input of the next ArcPower 144 until all fixtures are connected. In this way, up to 32 fixtures can be chained together.

At the last ArcPower 144 the data link has to be terminated with a terminator. A termination plug is simply a RJ45 connector with a 120 Ω resistor between pins Data (-) and Data (+). Plug terminator in the DMX output of the last ArcPower 144.

Maximum number of LEDs connected to the one ArcPower 144 zone is 42, (but maximum 12 LEDs per colour).

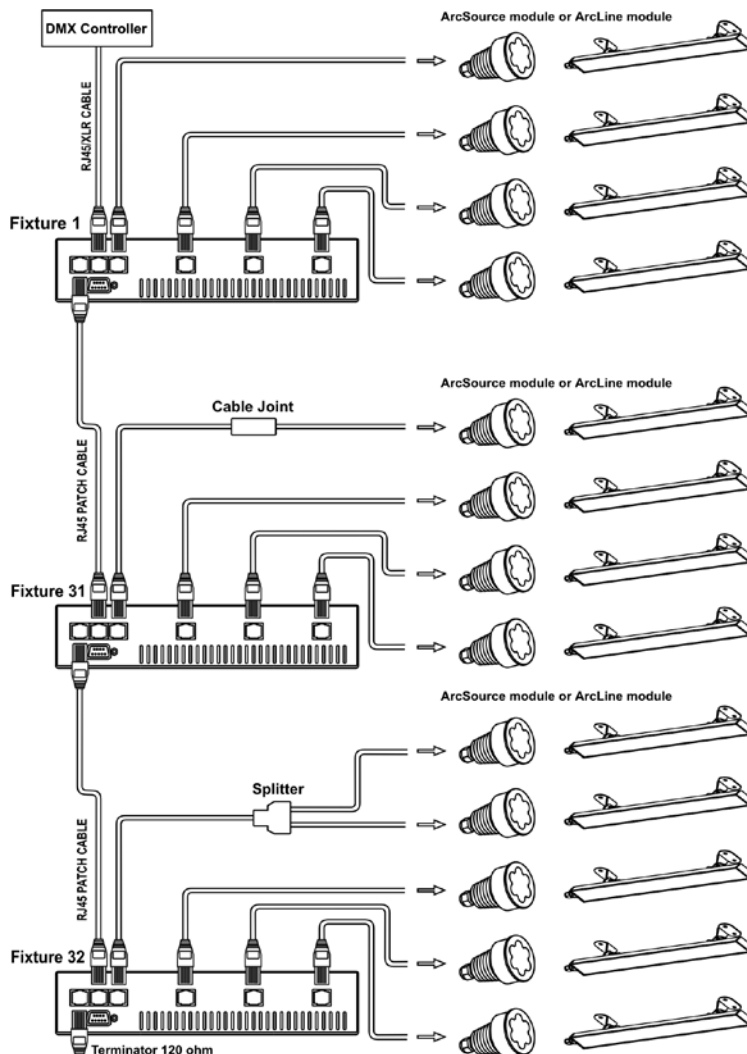

**Maximum possible number of LED modules connected to the one zone of ArcPower 144:**

Model	total LEDs	Red LEDs	Green LEDs	Blue LEDs	White LEDs	Max. number of connected modules
ArcLine 12 RGB	12	4	4	4	-	3
ArcLine 24 RGB	24	8	8	8	-	1
ArcLine 36 RGB	36	12	12	12	-	1
ArcLine Optic 12 RGB	12	4	4	4	-	3
ArcLine Optic 24 RGB	24	8	8	8	-	1
ArcLine Optic 36 RGB	36	12	12	12	-	1
ArcSource 3 RGB	3	1	1	1	-	12
ArcSource 6 RGB	6	2	2	2	-	6
ArcSource 12 RGB	12	4	4	4	-	3
ArcSource 7 RGBW	7	2	2	2	1	6

**Note:** You cannot combine RGB and RGBW modules (e.g. ArcSource 6 RGB and ArcSource 7 RGBW) each other because white LEDs will not light.

**5.2 Master-slave operating**

1. Unplug from the mains before installation.
2. Connect the LED module to the fixtures.
3. Connect the DMX output of the master fixture in the data-chain with the DMX input of the first slave. Always connect output with the input of the next slave until all slaves are connected. Up to 32 fixtures can be connected in master/slave chain
4. Insert the termination plug (with 120 Ohm) into DMX input of the master fixture and into the DMX output of the last slave fixture in the link in order to ensure proper transmission on the data link.
5. Connect the fixtures to the mains.
6. See chapter „Stand-alone mode” in order to set the fixture as a master or slave.

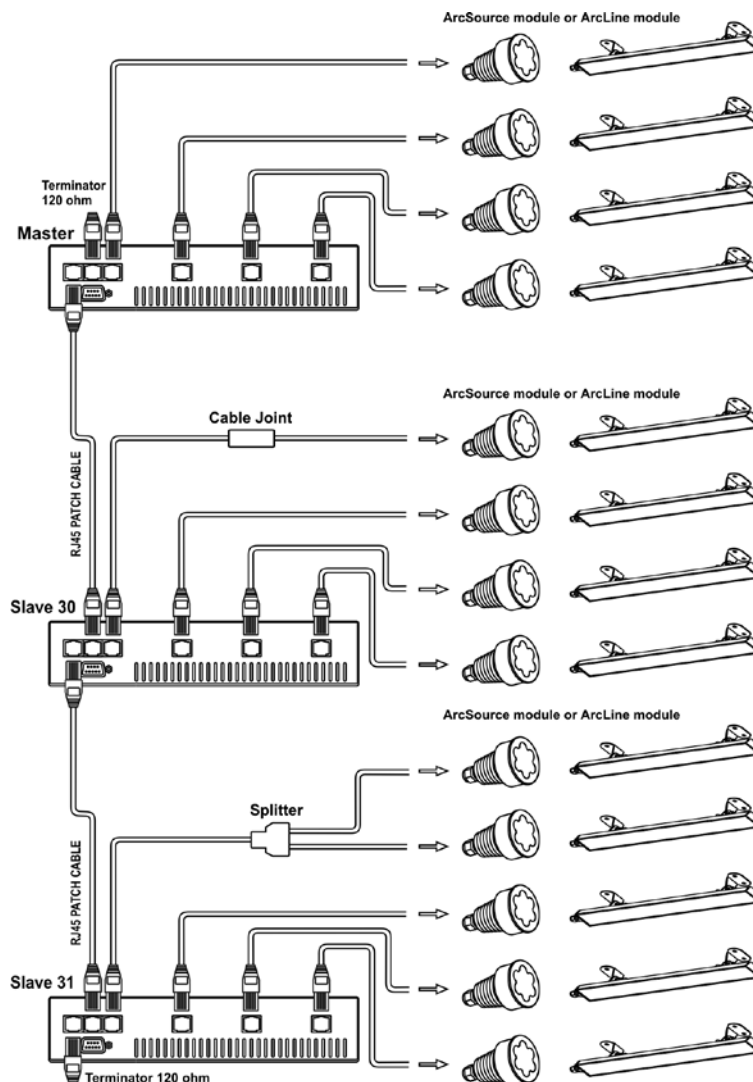



### 5.3. Operating via DyNet protocol

1. Unplug from the mains before installation.

2. Connect LED modules to the fixtures.

Connect first fixture to the control panel which uses DyNet protocol (e.g. DLP 8100)

3. Connect the DMX output of the first fixture in a data link with the DMX input of the second fixture. Always connect output with the input of the next fixture until all fixtures are connected. Up to 32 fixtures can be connected in data chain.

4. Insert the termination plug (with 120 Ohm) into DMX output of the last fixture in order to ensure proper transmission on the data link.

5. Connect fixtures to the mains

6. Select the DyNet protocol on all fixtures (menu "SPE"---> "dYn").

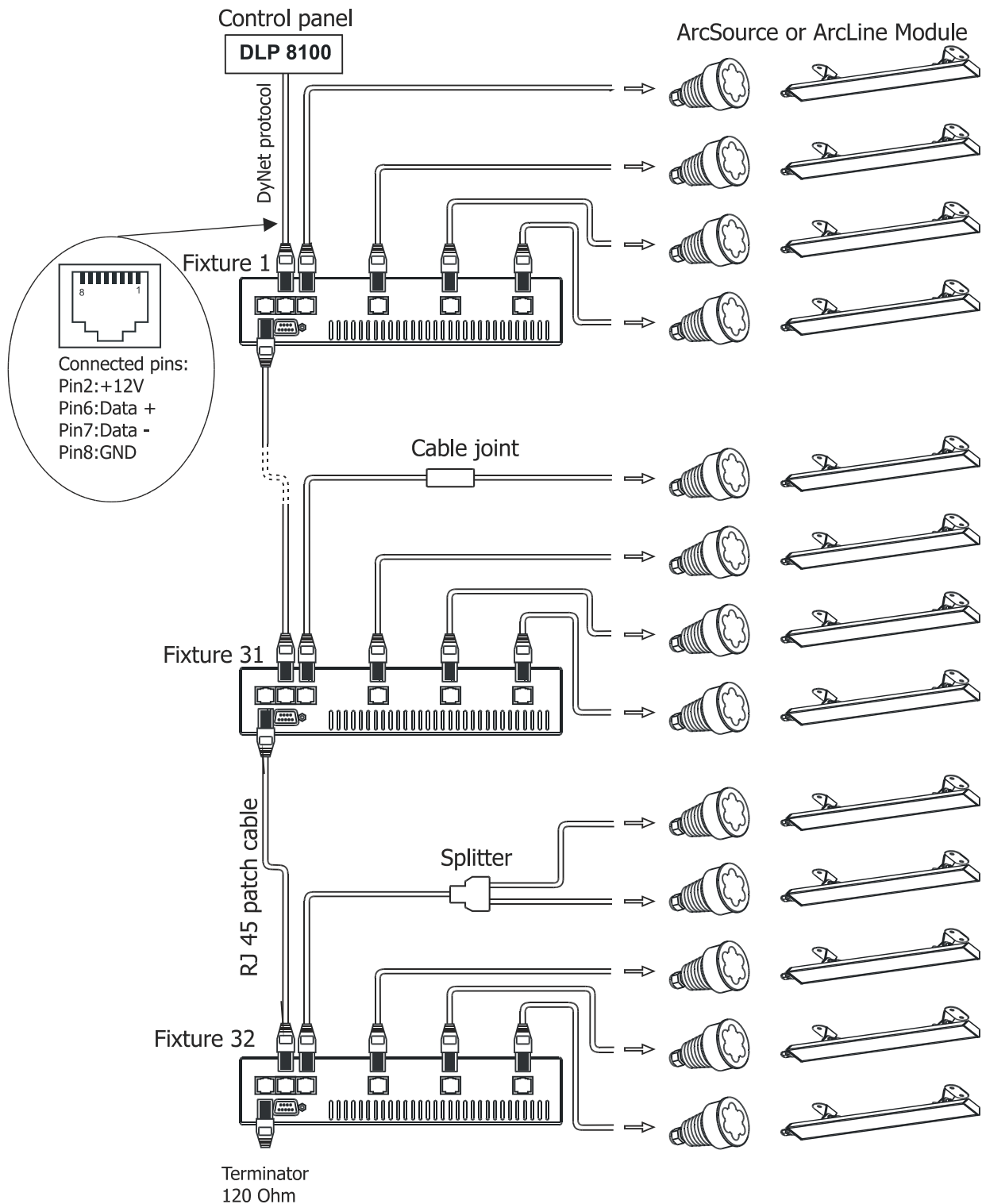

A description of each byte in DyNet protocol is the following:

Byte 0: 1C - hexadecimal Logical Message (fixed value)  
Byte 1: 01 - Area  
Byte 2: 00 - Channel level  
Byte 3: 80 - Channel  
Byte 4: ff - Channel Offset  
Byte 5: 00 - Fade Rate  
Byte 6: FF (fixed value)  
Byte 7: 1C Checksum

**Area** - (0 to 255), as set on the Arcpower to give a unique address for each Arcpower unit (i.e. DMX base address)

**Channel Level** - (0 to 255), level - 01=100%, FF=0%

**Channel** - (80 to 83), 80= channel 1, 81= channel 2, 82= channel 3, 83= channel 4, (see Channel Offset if more than 4 channels)

**Channel Offset** - (0-255), default (FF)- channel offset in blocks of 4: (FF = CH 1-4, 00 = CH 5-8, 01 = CH 9-12, etc up to 3E = CH 253-256 )

**Fade Rate** - (0-255), fade rate with 1 second resolution (0= 0 seconds, 255= 255 seconds)

**Checksum** - (0-255), checksum Byte - used to ensure the integrity of the packet.

Negative two's compliment of the preceding 7 bytes.

Example 1:

0x1C,0x10,0x00,0x80,0xff,0x05,0xff,0x52

This would control channel 1 (i.e. Red) of Arcpower unit, address 16 to a Level of 100% with a fade of 5 seconds.

Example 2:

0x1C,0x05,0xCC,0x82,0xff,0x0A,0xff,0x52

This would control channel 3 (i.e. Blue) of Arcpower unit, address 5 to a level of 20% with a fade of 10 seconds.

## 6. Control menu map

Default settings=**Bold print**

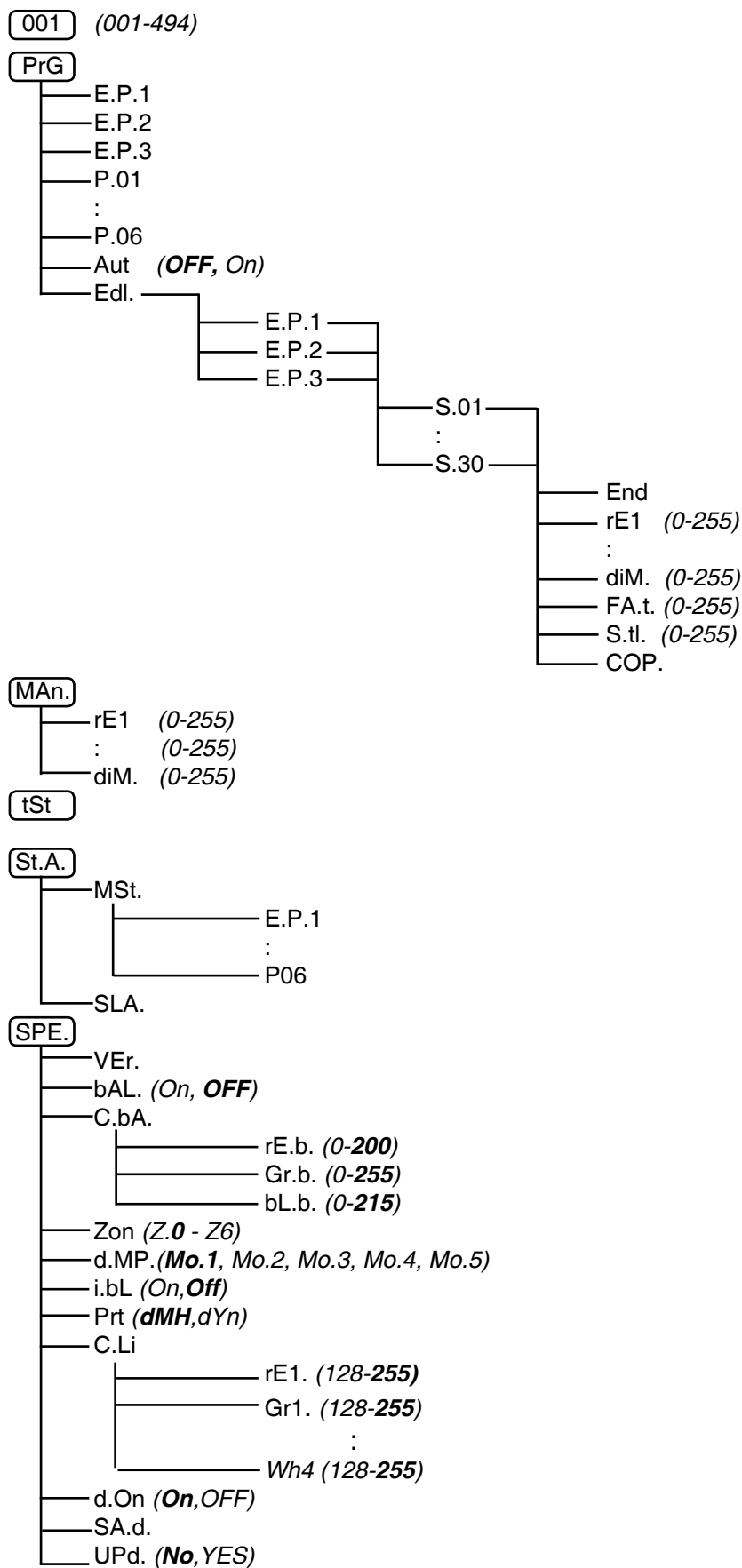

## 7. DMX protocol

version 2.1 (software version 5.3 and higher)

Mode/Channel					Value	Function	Type of control
1	2	3	4	5			
<b>ZONE 1</b>							
1	1	1	1	1	0-255	<b>Red LED 1</b> Red LED saturation control (0-100%)	proportional
2	2	2	2	2	0-255	<b>Green LED 1</b> Green LED saturation control (0-100%)	proportional
3	3	3	3	3	0-255	<b>Blue LED 1</b> Blue LED saturation control (0-100%)	proportional
	4	4		4	0-255	<b>White LED 1</b> White LED saturation control (0-100%)	proportional
<b>ZONE 2</b>							
4	5	5	1	1	0-255	<b>Red LED 2</b> Red LED saturation control (0-100%)	proportional
5	6	6	2	2	0-255	<b>Green LED 2</b> Green LED saturation control (0-100%)	proportional
6	7	7	3	3	0-255	<b>Blue LED 2</b> Blue LED saturation control (0-100%)	proportional
	8	8		4	0-255	<b>White LED 2</b> White LED saturation control (0-100%)	proportional
<b>ZONE 3</b>							
7	9	9	1	1	0-255	<b>Red LED 3</b> Red LED saturation control (0-100%)	proportional
8	10	10	2	2	0-255	<b>Green LED 3</b> Green LED saturation control (0-100%)	proportional
9	11	11	3	3	0-255	<b>Blue LED 3</b> Blue LED saturation control (0-100%)	proportional
	12	12		4	0-255	<b>White LED 3</b> White LED saturation control (0-100%)	proportional
<b>ZONE 4</b>							
10	13	13	1	1	0-255	<b>Red LED 4</b> Red LED saturation control (0-100%)	proportional
11	14	14	2	2	0-255	<b>Green LED 4</b> Green LED saturation control (0-100%)	proportional
12	15	15	3	3	0-255	<b>Blue LED 4</b> Blue LED saturation control (0-100%)	proportional
	16	16		4	0-255	<b>White LED 4</b> White LED saturation control (0-100%)	proportional



## 8.1 Addressing the ArcPower 144

The fixture can be operated in the two modes:

**DMX mode** - fixture is controlled via DMX 512 by an external DMX controller.

**Stand-alone mode** - fixture uses built-in programs and is able to control other fixtures in the master/slave chain. See the chapter „Stand-alone mode” for detail description.

For DMX mode is important the DMX start address that is defined as the first channel from which the ArcPower 144 will respond to the DMX controller.

### Setting the DMX start channel for DMX operating:

1. Connect ArcPower 144 to the mains.
2. Browse through the menu by pressing the [UP] and [DOWN] buttons until the display shows current address „001”. Confirm by pressing [ENTER] button and „001” will start to flash frequently.
3. Use the [UP] and [Down] buttons to select the desired address.
4. Confirm by pressing [ENTER].

After having addressed ArcPower 144, you may now start operating ArcPower 144 via your DMX controller.

## 8.2 Program running

By enter to this menu a complete overview of all programs is offered, from which the program to be run can be selected by pressing [ENTER]. Selected program runs in a loop. The fixture includes 6 built-in programs (P.01-P.06) and 3 free editable programs (E.P.1-E.P.3), each up to 30 steps.

If Item „AUT” is On, the fixture in DMX mode will remember last running program and this program will run after switching on the fixture.

Each program step has a fade time-the time during which effects go to the current step and a Standing time-the time, during which effects last in the current step.

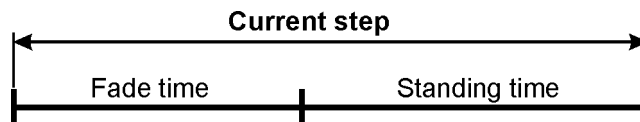

### Programming procedure:

1. Enter „Edl.” menu
2. Press [UP] or [DOWN] to select the desired program which you wish to edit and press [ENTER].
3. Press [UP] or [DOWN] to select the desired program step („S.01” - „S.30”) and press [ENTER].
4. Press [UP] or [DOWN] to select the desired item and press [ENTER]-button.

Now you can edit by using [UP] or [DOWN] buttons the DMX values selected item:

**End.** - a total number of the program steps (value 1-30). This value you must set before start programming (e.g. if you want to create program with 10 steps, set End=10).

<b>rE1</b>	- a red LED 1 saturation, value 0-255	<b>rE2</b>	- a red LED 2 saturation, value 0-255
<b>Gr1</b>	- a green LED 1 saturation, value 0-255	<b>Gr2</b>	- a green LED 2 saturation, value 0-255
<b>bL1</b>	- a blue LED 1 saturation, value 0-255	<b>bL2</b>	- a blue LED 2 saturation, value 0-255
<b>Wh1</b>	- a white LED 1 saturation, value 0-255	<b>Wh2</b>	- a white LED 2 saturation, value 0-255
<b>rE3</b>	- a red LED 3 saturation, value 0-255	<b>rE4</b>	- a red LED 4 saturation, value 0-255
<b>Gr3</b>	- a green LED 3 saturation, value 0-255	<b>Gr4</b>	- a green LED 4 saturation, value 0-255
<b>bL3</b>	- a blue LED 3 saturation, value 0-255	<b>bL4</b>	- a blue LED 4 saturation, value 0-255
<b>Wh3</b>	- a white LED 3 saturation, value 0-255	<b>Wh4</b>	- a white LED 4 saturation, value 0-255

### Following item are common for all zones:

- MAC.** - a macro selection, value 0-255
- Str.** - a strobe, value 0-255
- dim.** - a dimmer, value 0-255
- FA.t.** - fade time, value 0-255\*
- S.tl.** - standing time, value 0-255\*
- COP.** - copying the current prog. step to the next prog. step.  
Press [ENTER]-button to confirm adjusted value.

5. Repeat steps 3 and 4 for next prog. step. If you want to copy current program step to the next prog. step, select option „COP.” and confirm it by pressing [ENTER].

\* Both Fade time and Standing time use the same conversion table in order to convert DMX values.

### DMX values to time values:

DMX	Time [sec.]	DMX	Time [min.]	DMX	Time [min.]	DMX	Time [min.]	DMX	Time [min.]
1	0.1	50	4.2	105	18.4	160	42.7	215	77
2	0.4	55	5	110	20.2	165	45.4	220	80.7
5	2.5	60	6	115	22	170	48.2	225	84.4
10	10	65	7	120	24	175	51	230	88.2
15	22.5	70	8.2	125	26	180	54	235	92
20	40	75	9.4	130	28.2	185	57	240	96
25	62.5	80	10.7	135	30.4	190	60.2	245	100
30	90	85	12	140	32.7	195	63.4	250	104
35	122.5	90	13.5	145	35	200	66.7	255	108
40	160	95	15	150	37.5	205	70		
45	202.5	100	16.7	155	40	210	73.5		

Exact expression of the time value follows the formula: time [sec.] = (DMX value)<sup>2</sup>/10

### 8.3 Manual mode

This menu gives access to the control of the fixture channels by means of the control buttons.

Use [UP] and [DOWN] buttons until the display shows „MAN.” menu. Press [ENTER] button and by using [UP] and [DOWN] buttons select desired effect, press [ENTER] and and by using [UP] and [DOWN] buttons adjust desired DMX value for selected effect. Confirm by [ENTER].

- |            |   |            |   |
|------------|---|------------|---|
| <b>rE1</b> | - a red LED 1 saturation, value 0-255   | <b>rE2</b> | - a red LED 2 saturation, value 0-255   |
| <b>Gr1</b> | - a green LED 1 saturation, value 0-255 | <b>Gr2</b> | - a green LED 2 saturation, value 0-255 |
| <b>bL1</b> | - a blue LED 1 saturation, value 0-255  | <b>bL2</b> | - a blue LED 2 saturation, value 0-255  |
| <b>Wh1</b> | - a white LED 1 saturation, value 0-255 | <b>Wh2</b> | - a white LED 2 saturation, value 0-255 |
| <b>rE3</b> | - a red LED 3 saturation, value 0-255   | <b>rE4</b> | - a red LED 4 saturation, value 0-255   |
| <b>Gr3</b> | - a green LED 3 saturation, value 0-255 | <b>Gr4</b> | - a green LED 4 saturation, value 0-255 |
| <b>bL3</b> | - a blue LED 3 saturation, value 0-255  | <b>bL4</b> | - a blue LED 4 saturation, value 0-255  |
| <b>Wh3</b> | - a white LED 3 saturation, value 0-255 | <b>Wh4</b> | - a white LED 4 saturation, value 0-255 |
- MAC.** - a macro selection, value 0-255  
**Str.** - a strobe, value 0-255  
**dim.** - a dimmer, value 0-255

### 8.4 Test sequences

Use the item to run a special demo-test sequences without an external controller, which will show you some possibilities of using the fixture. The sequences are the same for all zones.

### 8.5 Stand-alone mode

Select this menu to set fixture behaviour in stand-alone mode without an external controller.

Synchronous operation of multiple fixtures requires that they must be connected on a data link and one of them is set as a master („MSt“) and the rest as the slaves („SLA“). Only one fixture can be set as the master. The slaves mimic the behavior of the master. Effect actions are triggered by an internal timer of the master fixture.

**Important!:** Disconnect the fixtures from the DMX controller before master/slave operating, otherwise data collisions can occur and the fixtures will not work properly!

**MSt.** --- Master. Enter this menu if you want to set the the fixture as a master. Use [UP] and [DOWN] buttons to select desired program and press [ENTER] to confirm selection.

**SLA.** --- Slave. Enter this menu if you want to set the the fixture as a slave.

The master fixture starts simultaneous program start in the other slave fixtures. All fixtures are synchronized in every prog.steps. The fixtures run their programs repeatedly (e.g. if master runs its program „P05“, all slaves

will be executed program „P05“ too).

Note: If the master runs its editable program (EP1,EP2 or EP3),all slaves will execute their own editable programs (EP1,EP2 or EP3) according the master,but both fade time (FA.t.) and standing time (S.tl.) for each step will be taken from the master´s step (slaves´ times are eliminated in each step).

## 8.6 Special functions **SPE.**

Use this menu for special services.

**Ver. - Software Version.** Select this function to read the number of the fixture software.

**bAL. - Balance.** Select this function to enable (On) or disable (OFF) the white balance which is set in „Colour balance“ menu below. If this function is set OFF, ArcPower 144 will use maximum values (100%) of saturation for red, green and blue channel.

**C.bA. - White colour balance.** Using this menu you can set white balance:

1. Browse through the menu by pressing the [UP] and [DOWN] buttons until the display shows „C.bA.“ menu. Press [ENTER] button and „rE.b.“ will appear on the display.
2. Press [ENTER] button again and use [UP] and [DOWN] buttons to adjust the new maximum value required for the red channel. Confirm your choice by pressing [ENTER]. Use the [UP] and [Down] buttons to select next colour.
3. Repeat step 2 for green channel „Gr.b.“ and for blue channel „bL.b“.

**Note:** Adjusted values are accepted for all LED outputs.

**Zon. - Zone selecting.**The option enables select desired number of the zone (from 0 to 6).

The number of the zone distinguishes individual zones of the ArcPower 144 which is controled via RS-232 interface.

Use [UP] and [DOWN] buttons to select desired zone and press [ENTER] to confirm selection. The selected zone number is assigned to the first LED output and the second one has its zone number by one number higher etc.

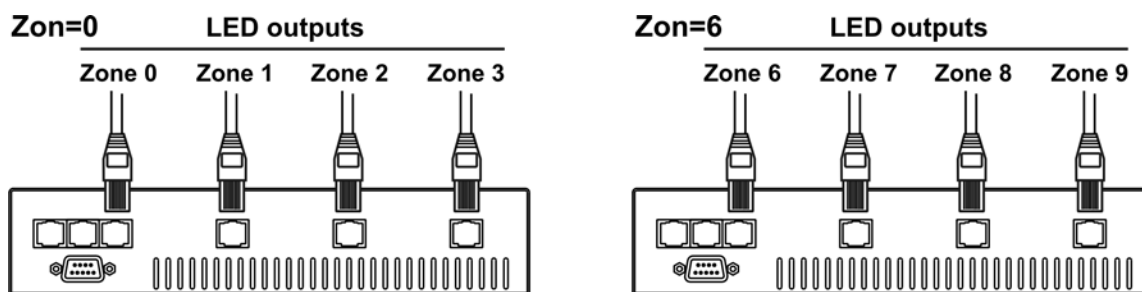

**d.MP. - DMX presetting.** The function makes possible to select from the 5 DMX channels settings. Use [UP] and [DOWN] buttons to select desired channel modes (“Mo.1, Mo.2,Mo.3, Mo.4, Mo.5”) and press [ENTER] to confirm.

For detail description of all channels see DMX protocol.

**i.bL. - Initial blink.** If this function is on, ArcPower 144 makes auto-calibration (All LEDs light on 100% for short time) after switching it on. If this function is set off, you have to set manually every colour on max. brightness after switching on the driver before starting regular operating. This action should last min. one second. In this moment, the ArcPower 144 finds out the load connected to its LED output and makes auto-calibration.

**Prt --- Protocol selection** - Selects a required communication protocol.

dMH - the fixture will communicate using DMX 512 signal.

dYn - the fixture will communicate using the DyNet protocol.

**C.Li. --- Current limiting.**The menu item allows to reduce a current-carrying capacity of each LED branch (colour) in order to keep a declared lifetime of LED modules.The situation can occur if you operate LED modules at an higher ambient temperature than is recommended (40°C).

The current-carrying capacity can be changed in a range of 350 - 175 mA (255-128) linearly.A default value is 255 (350 mA).

To adjust the current limiting:



1. Browse through the menu by pressing the [UP] and [DOWN] buttons until the display shows "C.Li." menu. Press [ENTER] button and "rE1" item will appear on the display.
2. Press [ENTER] button again and use [UP] and [DOWN] buttons to select desired value. Confirm this value by pressing [ENTER]. Use the [UP] and [Down] buttons to select next colour.
3. Repeat step 2 for next items "Gr1", "bL1", "Wh1"..... "rE4", "Gr4", "bL4", "Wh4".

**d.On.** --- **Display permanent on** - If this item is set On, the fixture's display lights permanent. If this item is OFF, the display will be extinguished 2 minutes after last button pressing.

**SA.d.** --- **Safe as default** - If you press this item, the current DMX value for each effect will be saved to driver's memory. These values will be used in the following cases:

- break of receiving DMX
- after switching the driver on without receiving DMX

**UPd.** - **Software update** - Using this function you can update software in the fixture via PC and serial link.

The following are required in order to update software:

- PC running Windows 95/98/2000/XP or Linux
- DMX Software Uploader
- Flash cable RS232/DMX (No.13050624)

**Note1:** Software update should execute a qualified person. If you lack qualification, do not attempt the update yourself and ask for help your ANOLIS distributor.

**Note 2:** DMX address, programs and all settings will be set to their default values.

#### **To update software in the fixture:**

##### **- Installation of DMX Software Uploader:**

1. DMX Software Uploader program is available from the ANOLIS web site at [www.anolis.cz](http://www.anolis.cz).
2. Make a new directory (e.g. Anolis\_Uploader) on your hard disk and download the software to it.
3. Unpack the program from the archive. Program file has name: DSU\_name of corresponding fixture\_SoftwareID. SoftwareID describes the versions of fixture software included in DMX Software Uploader. Higher number means later software versions.

##### **- Fixture software updating:**

1. Determine which of your COM port is available on your PC and connect it with to the DMX input of the fixture using the Flash cable. Do not extend this cable! Disconnect the fixture from the other fixtures in DMX chain! Turn on the computer and the fixture.
2. Switch the fixture to the update mode by selecting the option Software update in menu Special Functions on the fixture control panel: SPE-->UPd-->yES. (From this option you cannot return back to the main menu. If you do not want to continue in software update, you have to switch off and on the fixture to leave this option!)
3. It is recommended that you exit all programs before running the Software Uploader.
4. Start the Software Uploader program. Select desired COM and then click Connect button. If the connection is OK, click Start Uploading button to start uploading. It will take several minutes to perform software update. All processors will be updated (including processors with the same software version).  
If you wish to update only later versions of processors, enable the Incremental Update check box. Avoid interrupting the process. Update status is being displayed in the list window. When the update is finished, the line with the text „The fixture is successfully updated” will appear in this window and the fixture will reset with the new software.

**Note:** In the case of interruption of the upload process (e.g. power cut), the fixture remains in the update mode and you have to repeat the software update again.

**For example:** The fixture was switched off before finishing software upload. After switching the fixture on again, the fixture is still in the update mode and the display is dark. Restart the Software Uploader program and repeat software update from your PC.

## 9. Control of the ArcPower 144 via RS-232

### 9.1 Wiring an RS-232 serial port

9-pin D connector (male)  
Front view of the socket:

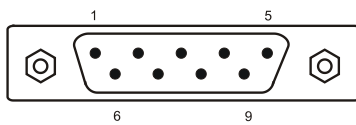

- Pin 1: Not connected
- Pin 2: Received Data
- Pin 3: Transmitted Data
- Pin 4:
- Pin 5: Signal Ground
- Pin 6:
- Pin 7:
- Pin 8:
- Pin 9: Not connected

### RS-232 cable:

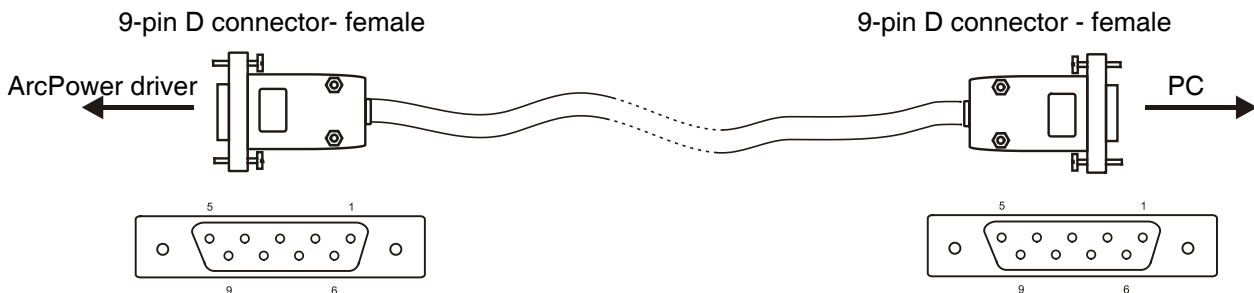

- |                         |                         |
|-------------------------|-------------------------|
| Pin 1:                  | Pin 1:                  |
| Pin 2: Received Data    | Pin 2: Received Data    |
| Pin 3: Transmitted data | Pin 3: Transmitted data |
| Pin 4:                  | Pin 4:                  |
| Pin 5: Signal ground    | Pin 5: Signal ground    |
| Pin 6:                  | Pin 6:                  |
| Pin 7:                  | Pin 7:                  |
| Pin 8:                  | Pin 8:                  |
| Pin 9:                  | Pin 9:                  |

The maximum cable length according to the standard is 15 metres or the cable length equals to a capacitance of 2500 pF.

### 9.2 Selecting a zone

The number of the zone distinguishes individual drivers which are controlled via RS-232 interface. Select **SPE** in main menu of the ArPower 144, press [ENTER], use [UP] and [DOWN] buttons to select **Zon**. The option enables to select desired number of the zone (from 0 to 6). Press [ENTER], use [UP] and [DOWN] buttons to select zone number and press [ENTER] to confirm selection.

### 9.3 Setting a serial port of PC

The serial port of your personal computer should be configured as follows:  
9600 Baud, 8 Data Bits, Non Parity, One Stop Bit, No Flow Control Required.

### 9.4 Zone commands

The ArcPower 144 uses the 3 types of the zone commands which can be used in a suitable software running on PC.

All zone commands stated below have to be send to the ArcPower 144 in ASCII codes.

#### Type 1: Selection of the preset colours

The syntax of the command is:

**zone Z red;**  
**zone Z green;**

**zone Z blue;**  
**zone Z white;**  
**zone Z yellow;**  
**zone Z cyan;**  
**zone Z magenta;**  
**zone Z blackout;**

**Z** .....means number of the zone (0-9)

**red/green/blue/white/yellow/cyan/magenta**....determines colour

**blackout**.....closes light output

**;**.....means end of character sequence

Examples: zone 3 green;  
          zone 0 blackout;

### **Type 2: Colour mixing-RGB**

The syntax of the command is:

**zone Z r,g,b;**

**Z**..... means number of zone (0-9)

**r** .....means DMX value of the red colour(0-255)

**g** .....means DMX value of the green colour (0-255)

**b** .....means DMX value of the blue colour (0-255)

**;** .....means end of character sequence

**,** .....values of colours have to be separated by a comma.

Examples: zone 0 234,126,165;  
          zone 1 5,18,28;

### **Type 3: Colour mixing-RGBW**

The syntax of the command is:

**zone Z r,g,b,w;**

**Z**..... means number of zone (0-9)

**r** .....means DMX value of the red colour(0-255)

**g** .....means DMX value of the green colour (0-255)

**b** .....means DMX value of the blue colour (0-255)

**w** .....means DMX value of the white colour (0-255)

**;** .....means end of character sequence

**,** .....values of colours have to be separated by a comma.

Examples: zone 0 156,145,171,211;  
          zone 1 5,18,28,148;

## 10. Technical Specifications

### Power supply:

Input Voltage: 100-240 V AC, 50/60 Hz

Fuse: T 3.15A H

Max. Power Consumption: 240VA

### Input:

Control: DMX 512 or DyNet

DMX connection: RJ45

RS 232 connection: 9-pin D connector

### DMX channels:

Mode 1: 12 channels

Mode 2: 16 channels

Mode 3: 19 channels

Mode 4: 3 channels

Mode 5: 4 channels

### Output:

4 LED Outputs

Max. Output Voltage: 48V DC

Max. Output current per zone: 350mA per colour

Max. load per zone: 36 LED's in RGB mode, 42 LED's in RGBW mode

Total load : 144 LED's in RGB mode

168 LED's in RGBW mode

### Maximum total cable length between one LED zone output all its connected LED modules:

80 metres at max. load .

### Control and programming:

Protocol: USITT DMX-512

Control options: DMX, Auto-trigger

Operation modes: Master/Slave, Stand alone

Programs: 6 build-in programs+3 user editable programs up to 30 steps each

Display: 3 digit LED

White colour balance adjusting

Manual control of all DMX channels by LED control panel

### Operating temperature:

-10°C/+40°C

Weight: 2.9 kg

Dimensions (mm):

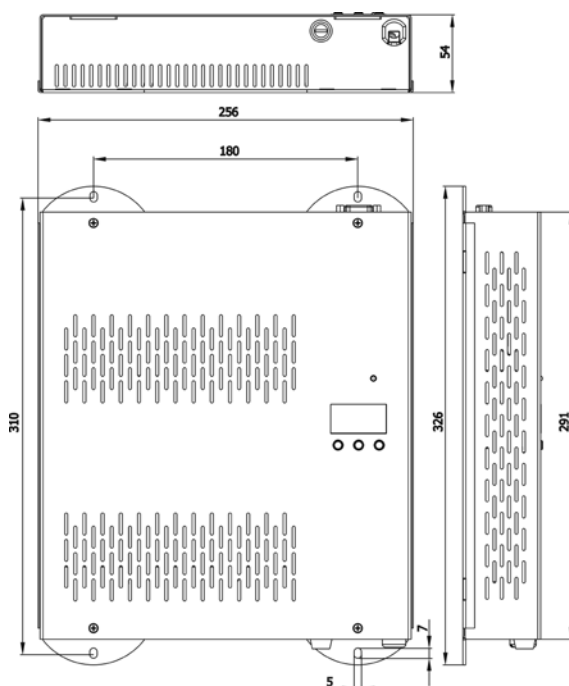

**Accessories:** Cable joint (No.: 13050691): 4 pieces

**Optional accessories:**

Adaptor RJ45/DMX 3 pin.....No.13050730  
Adaptor RJ45/DMX 5 pin.....No.13050731

## **11. Replacing the fuse**

**1. Before replacing the fuse, unplug mains lead!**

2. Unscrew the fuse holder on the rear side of the ArcPower 144 with a fitting screwdriver from the housing (anti-clockwise).
3. Remove the old fuse from the fuse holder.
4. Install the new fuse in the fuse holder.
5. Replace the fuse holder in the housing and fix it.

***Specifications are subject to change without notice.  
June 27, 2012***

