

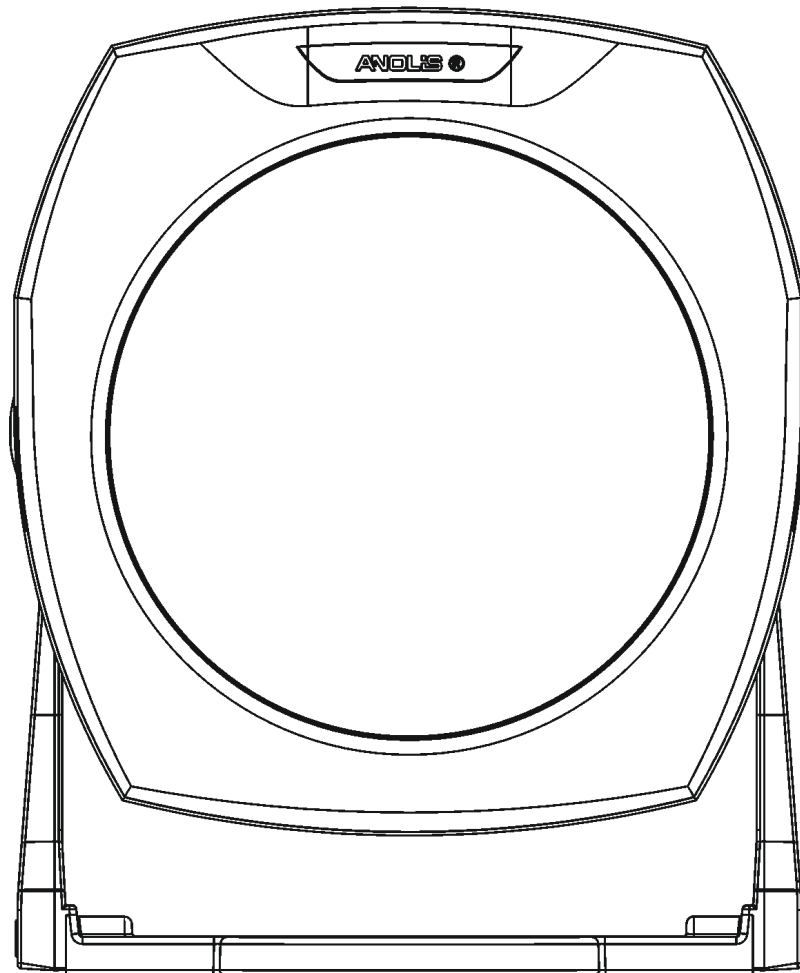

ArcSource 24 MC Submersible



ArcSource 24 MC Submersible

Table of contents

1. Introduction	3
2. Safety information	3
3. Mounting.....	3
4. ArcSource 24 MC Submersible connection with a control unit.....	4
5. Technical specifications.....	5
6. Mounting the ArcSource 24 MC Submersible into installation sleeve..	7
7. Cleaning and maintenance	7

1. Introduction

The ArcSource 24MC Submersible has a housing crafted from the highest quality marine grade bronze meaning its is capable to withstand the very harshest environmental conditions.

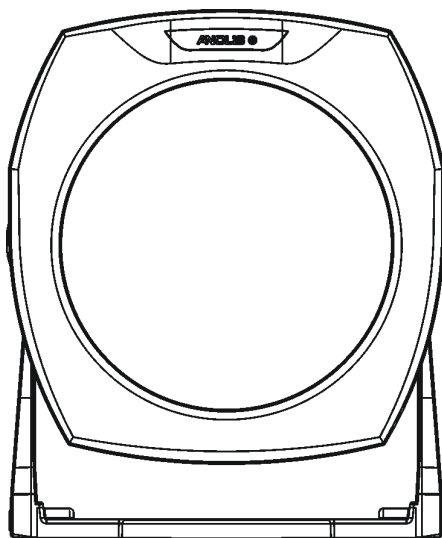

2. Safety information

The unit must be installed by a qualified electrician in accordance with all national and local electrical and construction codes and regulations.

Do not install the module near high inflammable liquids or materials

Do not allow anything to rest on the module

Do not install the module near the naked flames

Do not install the module in dirty, dusty or badly ventilated location

Avoid using the unit in locations subject to possible impacts.

The unit is suitable for underwater installation up to depth of 10 m.

Do not let the unit in frozen water

Avoid looking directly into the LED light beam at close range.

3. Mounting

The ArcSource 24 MC Submersible can be arranged in any position orientation. The LED module body is mounted on a bronze bracket for "tilt" adjustment . Use a spanner no.13 (pos.1) and Allen key no.6 (pos. 2) to adjust desired tilt position of the LED module. For fastening the ArcSource 24 MC Submersible to the flat surface use either three holes or two semicircle slots which allows fine adjusting the fixture in a "pan" direction.

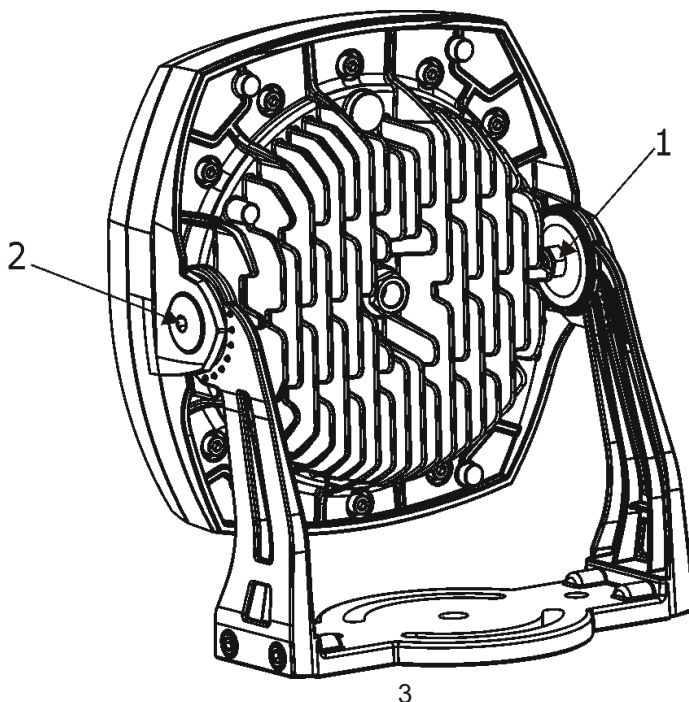

Wiring of the ArcSource 24 MC Submersible:

Wire	Red wire	Blue wire	Orange wire
Meaning	+24V	Ground	Communication

4. ArcSource 24 MC Submersible connection with a control unit

Maximum distance between the ArcPower 24 MC (24V) and the ArcSource 24 MC Submersible should must not exceed 50 metres.

Connect the ArcSource 24 MC Submersible to the control unit ArcPower 24 MC (24V) according the picture below. For more information see the ArcPower 24 MC (24V) user manual.

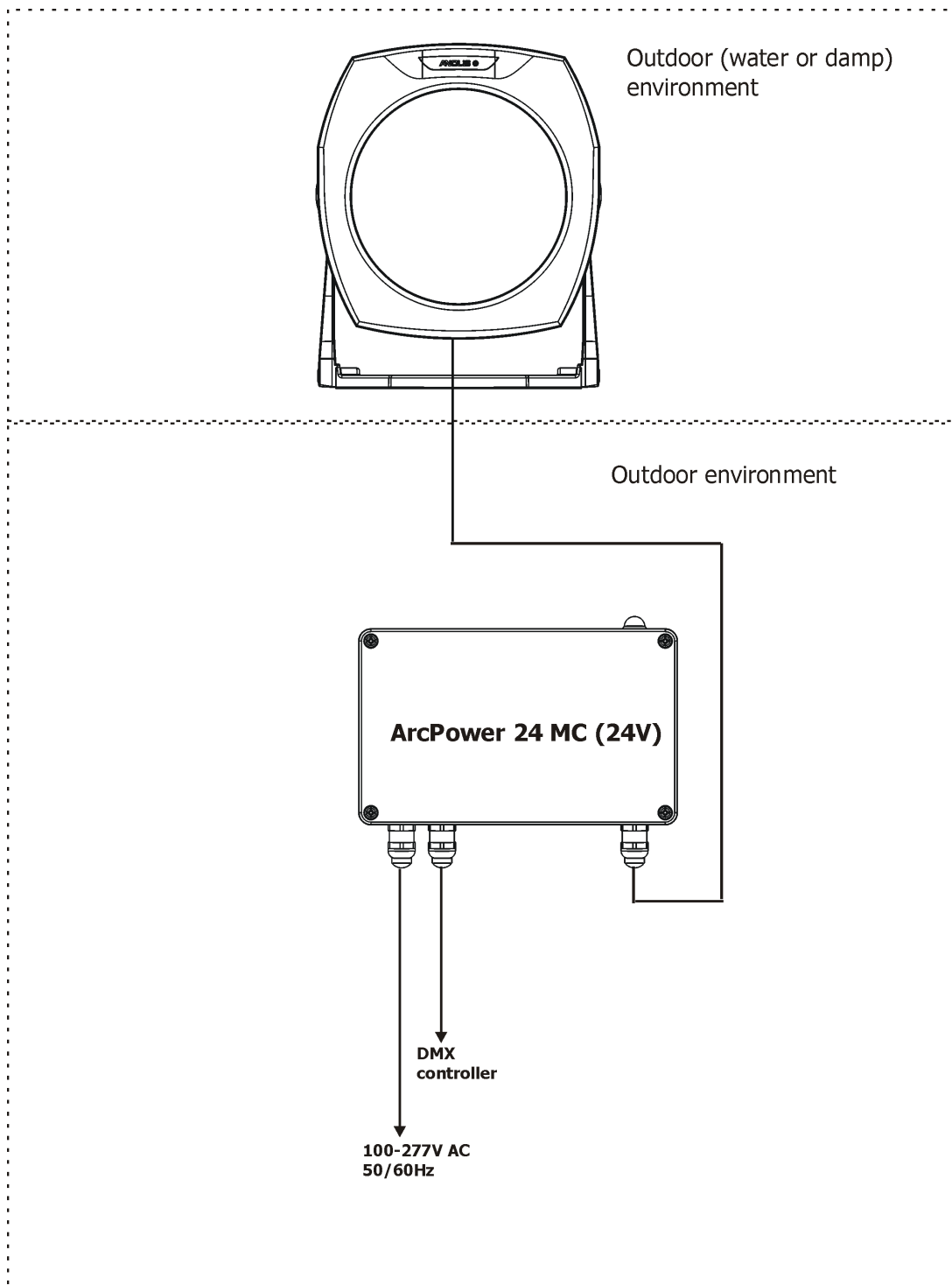

5. Technical specifications

Light source:	6 x 10W multichip LEDs
Input voltage :	24 V DC
Maximum power consumption:	35W (Standard Mode, 350mA), 75W (High Power Mode, 700mA)
Max. current (per colour):	700 mA
Compatible control unit:	ArcPower 24 MC (24V)
Typical Lumen maintenance:	60 000 hours
Cooling system:	Convection
Available beam angles:	7°, 24°, 34°, 60°
Colour variants:	RGBCW, CW, SW
Protection factor:	for CE: IP68 10m rating for cETLus: maximum depth of 10 m.
Impact rating:	IK10
Construction:	Marine bronze, transparent cover-tempered glass
Weight:	10.5 kg (23.1 lbs)
LED module tilt adjustment range:	125°
Mounting options:	Stirrup
Connecting cable (custom length):	CE: PROFIPLAST PBS-USE 3 X 1.5 mm ² BLACK (P/N13052450) cETLus: P7342-SP-600V RND PORTAVLE CORD RUBBER 50mtr (P/N 13052148)
Operating ambient temperature:	-20°C +40°C (-4°F +104°F)
Optional accessories:	Installation sleeve (P/N 10980285) Floor Stand ArcSource 24 MC Submersible 5mm (P/N10980315)

Dimensions (mm)

ArcSource 24 MC Submersible

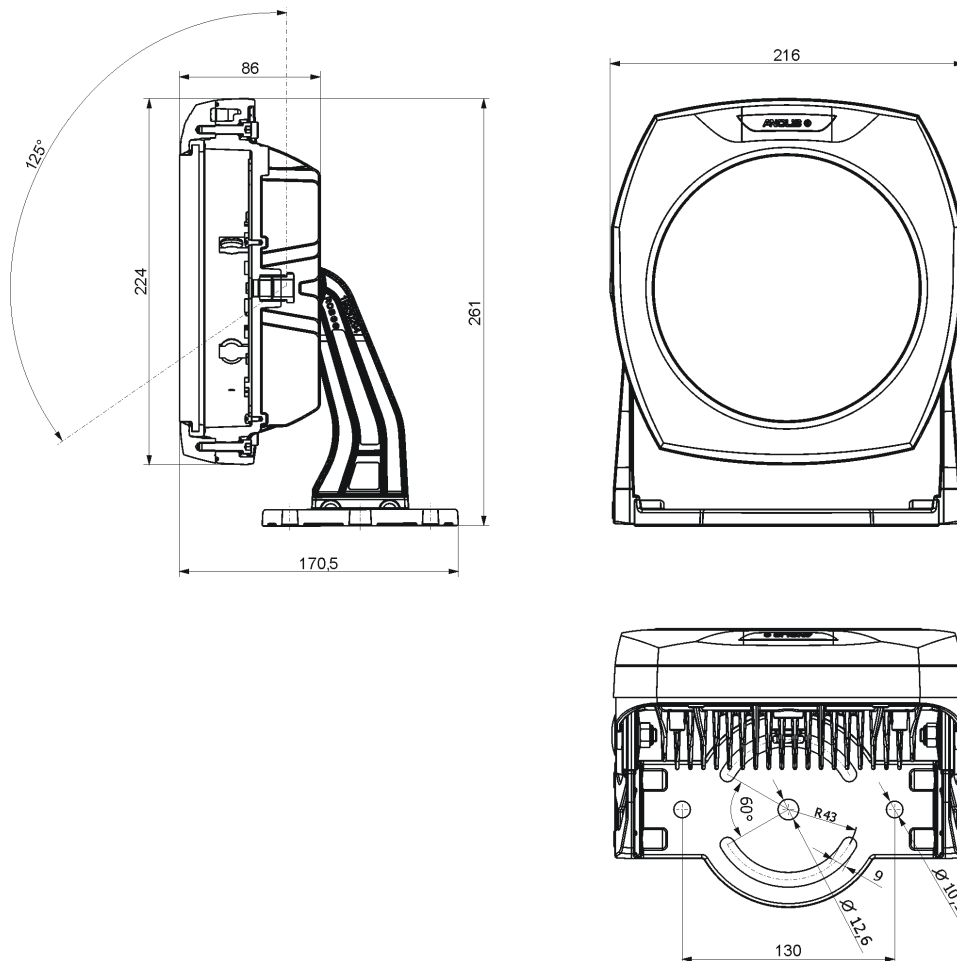

Installation sleeve

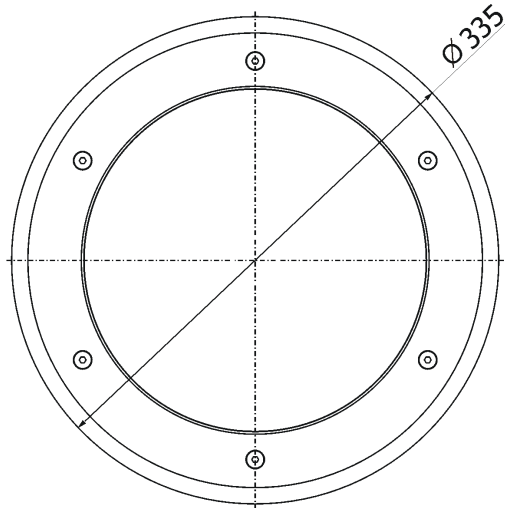
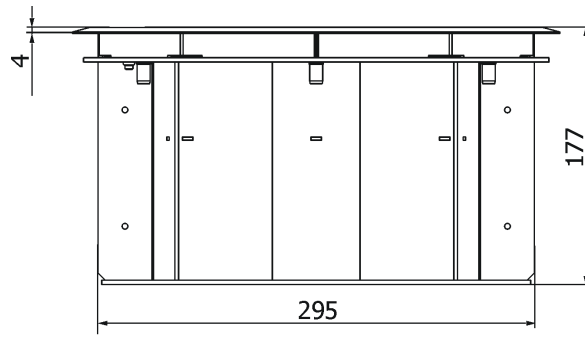

Weight: 10 kg

6. Mounting the ArcSource 24 MC Submersible into the installation sleeve

1. Unscrew a bracket from the ArcSource 24 MC Submersible.
2. Insert the ArcSource 24 MC (4) Submersible into chassis (5) and fasten it on both sides it by means of two bolts (7) with rubber washers (6), 6 mm long spacers (10) and nuts M8 (9). These parts (6,7,9,10) are components of the installation sleeve (8).
3. Insert Allen bolts M5x45 (1) with spring washers (2) to the 30mm spacers (3) and used them to screw the chassis (5) to the installation sleeve (8) (before inserting chassis, pull the ArcSource 24 MC Submersible's cable through the aperture in the installation sleeve).
4. Screw the metal collar (13) to the chassis (5) with two Allen keys M4x12 (11) and washers (12).
5. Insert the flat rubber gasket (14) into metal collar (13).
6. Put the glass (15) on the rubber gasket (14).
7. Put the shaped rubber gasket (16) on the glass (15).
8. Screw the top metal flange (17) by means of the six flat head screws M6x30 (18) to the installing sleeve.
9. Connect the ArcSource 24 MC Submersible to the ArcPower 24 MC (24V).

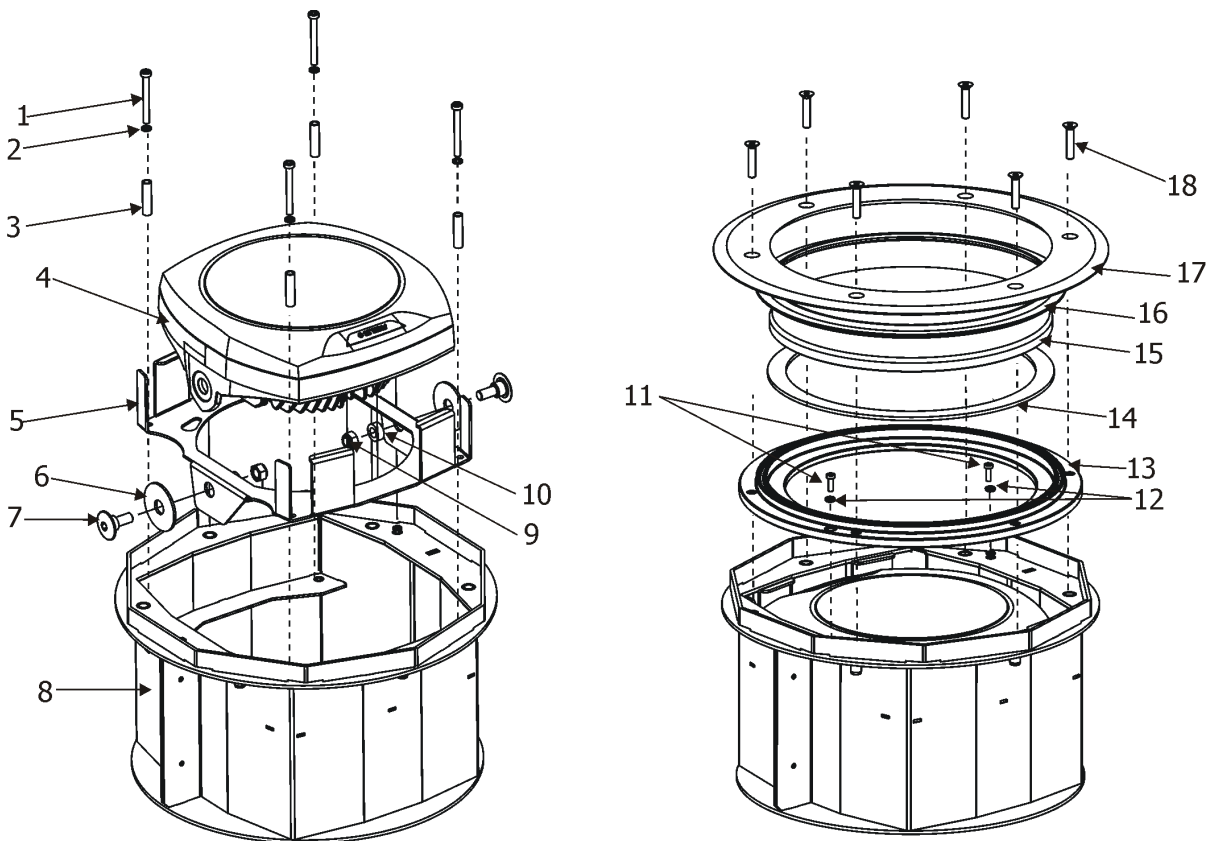

7. Cleaning and maintenance

Disconnect from the mains before starting any maintenance work

Rinse off loose dirt with low pressure water spray. Wash the housing with a soft brush or sponge and a mild, non-abrasive washing detergent. Rinse it.

There are no serviceable parts inside the device.

Maintenance and service operations are only to be carried out by a qualified person.

Should you need any spare parts, please use genuine parts.

May 17, 2018

Specifications are subject to change without notice.

Made in CZECH REPUBLIC by ROBE LIGHTING s.r.o. Palackeho 416/20 CZ 75701 Valasske Mezirici

