

Divine™ 60 UV



Client: _____

Project: _____

Specifier: _____

Type: _____ QTY: _____

FEATURES:

- Almost undetectable luminescence at normal lighting frequencies
- Powerful output for indoor & outdoor effects
- Input Voltage: 100 - 277 V AC 50/60 Hz
- Power Consumption: 180 W +/- 10 %
- Light Source: 60 x UV LEDs
- Projected Lumen Maintenance: 16.000 hrs (L70 @ 77 °F / 25 °C)
- Control: Third Party DMX Controllers
- IP Rating: IP67
- 2 Years Warranty

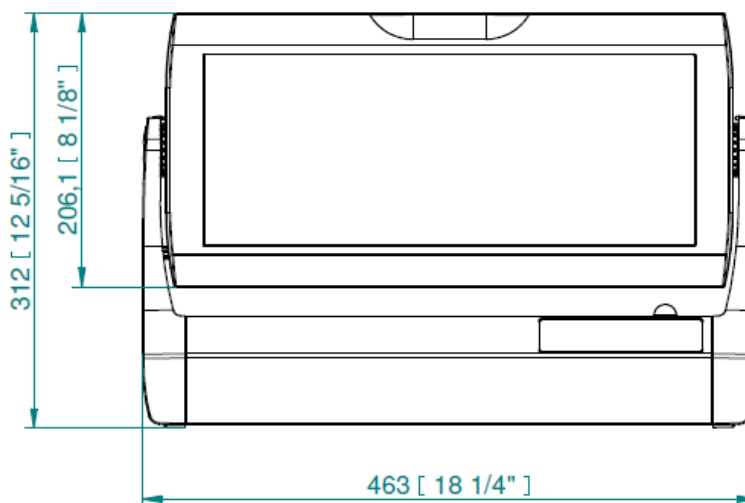
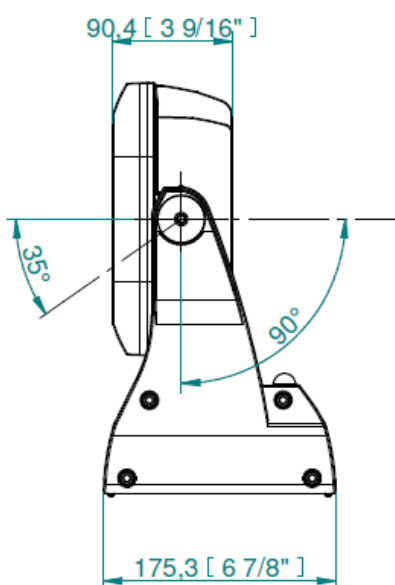

Specification:

ELECTRICAL	Input Voltage	100 - 277 V AC 50/60 Hz
	Typical Power Consumption	180 W +/- 10 %
	Inrush Current	30 A @ 230 V, 20 A @ 115V
OPTICAL	Light Source	60 x UV LEDs
	Wave Length	365 nm (peak)
	Beam Angle	38°
	Projected Lumen Maintenance	16.000 hrs (L70 @ 77 °F / 25 °C)
CONTROL	Display	LED Display (Inside Integrated Junction Box)
		Chassis Mounted LED Display (Optional)
	Wireless DMX	Lumen Radio CRMX Technology (Optional)
	Interface Protocol	USITT DMX512, RDM
	Control System	Third Party DMX Controllers
	Operating Modes	DMX, Stand-alone
	DMX Modes	3
	DMX Channels	2, 3, 9
	Programs / Functions / Features	Editable Program: 1 (up to 40 steps)
	Settings / Addressing	Via LED Display with Control Buttons or RDM
	Power Supply	Integrated
PHYSICAL	Width x Height x Depth	463 x 314 x 175 / 237 mm (18.2 x 12.4 x 6.9 / 9.3 in.)
	Weight	14.5 kg / 32 lbs
	Housing	High Pressure Die-Cast Aluminium Body
		Tempered Glass
	Finish Options	Standard Colour - Graphite Black (RAL 9011), Silver (RAL 9006)
		Cost Option - Custom RAL
	Cables / Connections	Integrated Junction Box With Terminal Block
		Recommended: Li9Y11Y 3 x AWG16 + 1(2xAWG24)
	Mounting Method	Surface Mount, Flush (J-Box), C-Clamp (For Side Connection Only)
	Adjustability	+35° / -90°
	Protection Factor	IP67 / Suitable For Wet Locations
	IK Rating	IK10
	Cooling System	Convection
	Operating Ambient Temperature	-20 °C / +40 °C (-4 °F / +104 °F)
	Operating Temperature	+70°C @ Ambient + 40°C (+158°F @ Ambient + 104°F)
Total Heat Dissipation	680 BTU/h (calculated)	
CERTIFICATION	Listings	ETL / cETL, CE, RoHS

ACCESSORIES	Surface Mount Adaptor (Included)
	Top Hat Divine 60 UV
	Half Top Hat Divine 60 UV
	Wire Guard/Anti-Glare Divine 60 UV
	Adaptor w/ Black Glass for Divine 60 UV
	Set of Rubber Feet
	C-Clamp Adaptor Divine (for side conn. only)
	Single Top Loader Case Divine

Connection:

1. Unscrew the eight screws (2) on the terminal block cover (1) to get access to the terminal block and control display (6) with four control buttons (7).
2. Unscrew both cable glands (4) from the terminal block cover (1) and both blind flanges (10) from the fixture base.
3. Apply an adequate layer of the paste LOCTITE 5331 on the plastic holder of the cable gland before inserting it into the body of the gland. Apply an adequate layer of the paste LOCTITE 577 on the thread of the gland body. Screw both cable glands (4) back into the terminal block cover (1) - see the picture below.
4. Apply an adequate layer of the paste LOCTITE 577 on the thread of the blind flange. Screw both blindflanges (10) back into the fixture base.

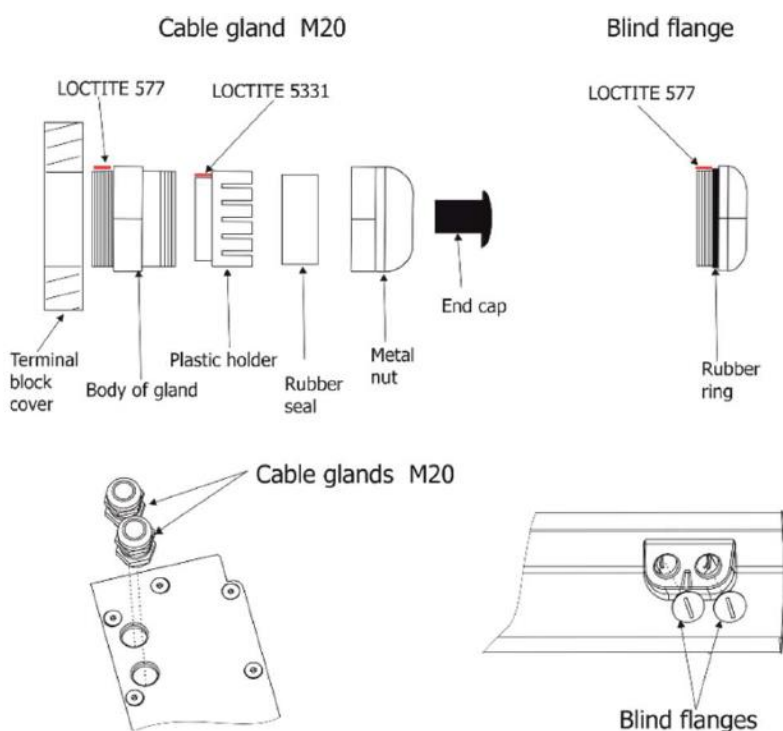

5. Pass the power/data cable through one cable gland (4) and connect to the terminal block.
6. Remove end cap (3) from cable glands before passing cable into the terminal block compartment. The two cable glands serve for cables of diameter of 5-10 mm. To keep declared IP rating, every cable gland has to be covered with an end cap (3) if the cable gland is not used for cable passing.

Note: If you are interchanging cable glands (4) and blind flanges (10), do not forget to apply LOCTITE 5331 and 577 on cable glands and LOCTITE 577 on blind flanges.

7. After connecting cables and setting the fixture by means of the control display and four buttons, place the cover (1) on the terminal block back, make sure the seal (5) is inserted correctly.
8. Screw the terminal block cover (1) with eight screws using a tightening torque of 4 Nm.
9. Check that all cable glands and screws and blind flanges are firmly secured.

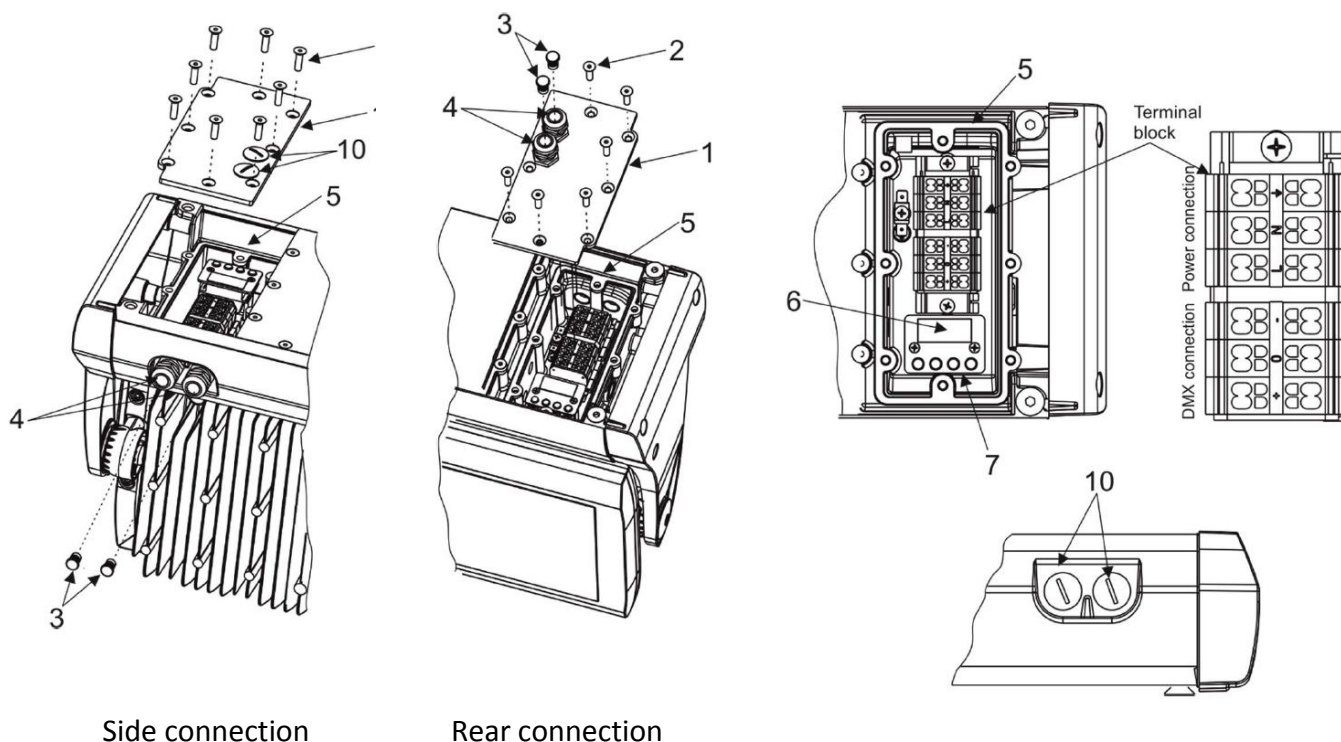

Labels:

Side connection shown

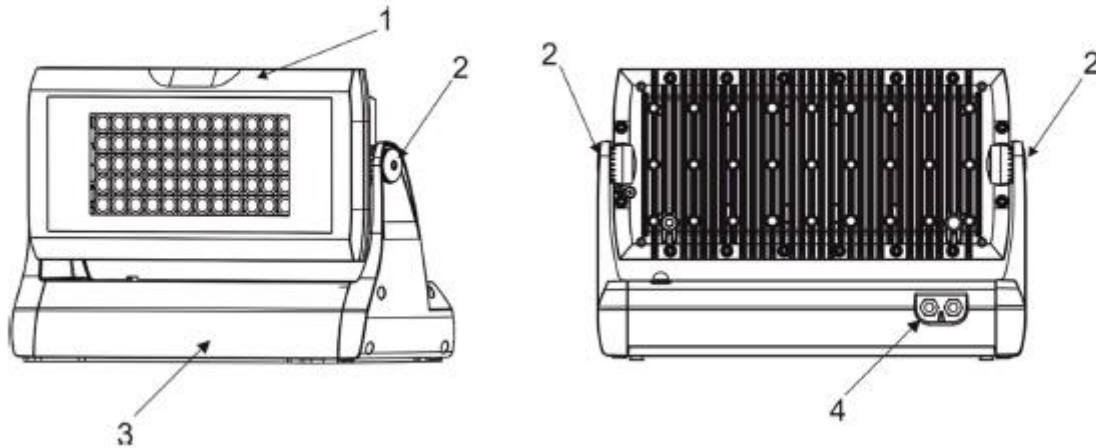

Rear connection shown

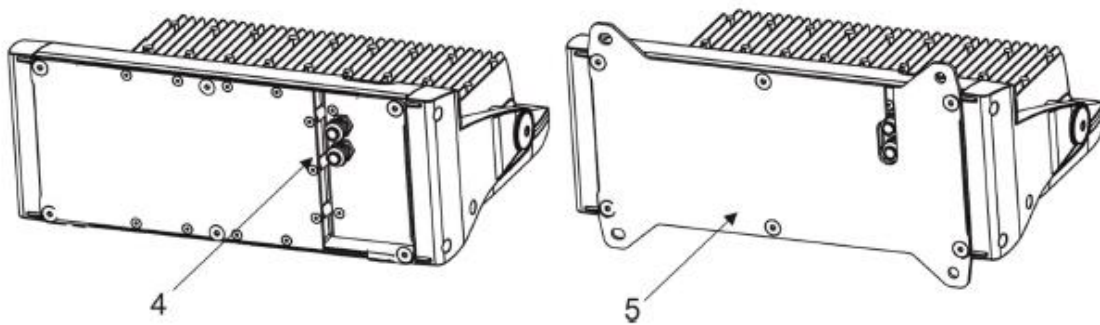

1. Head with LED array
2. Tilt lock
3. Base
4. Cable glands or blind flange
5. Surface mounting adapter

Note: customer can interchange the cable glands and blind flanges in the fixture base to create a side or rear connection.