

Ambiane XP56 Pendant Remote

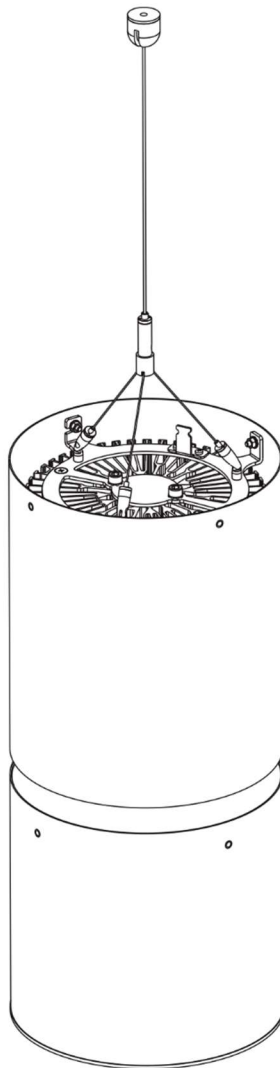

Version 1.3

Table of contents

1. Attention.....	3
2. Fixture exterior view.....	4
3. Installation.....	4
3.1. DMX and DALI address setting and control.....	8
3.2 0-10V control.....	9
4. RDM.....	9
5. DMX protocol.....	10
6. Technical specifications.....	11
7. Cleaning and maintenance.....	13
7.1 Software update.....	13
7.2 Disposing of the product.....	16

1. Attention

The unit must be installed by a qualified electrician in accordance with all national and local electrical and construction codes and regulations.

The unit was designed for indoor use only.

Do not install the unit near highly inflammable liquids or materials.

Do not allow anything to rest on the unit.

Do not install the unit near an open flame.

Do not install the unit in dirty, dusty or badly ventilated location.

Avoid looking directly into the light beam at close range!

A ceiling (structure) intended for installation of the unit(s) must safely hold weight of the unit(s) placed on it.

Immunity of the equipment is designed for electromagnetic environments E1, E2, E3 according to the standard EN55103-2 ed.2 Electromagnetic compatibility. Product family standard for audio, video, audiovisual and entertainment lighting control apparatus for professional use. Part 2: Immunity.

The product (covers and cables) must not be exposed to a high frequency electromagnetic field higher than 3V/m.

The installation company should check levels of possible interferences above the tested levels E1,E2,E3 given by this standard (e.g. transmitters in surrounding area) before installing the equipment.

Emission of the equipment complies with the standard EN55032 Electromagnetic compatibility of multimedia equipment – Emission Requirements according to class B.

2. Fixture exterior view

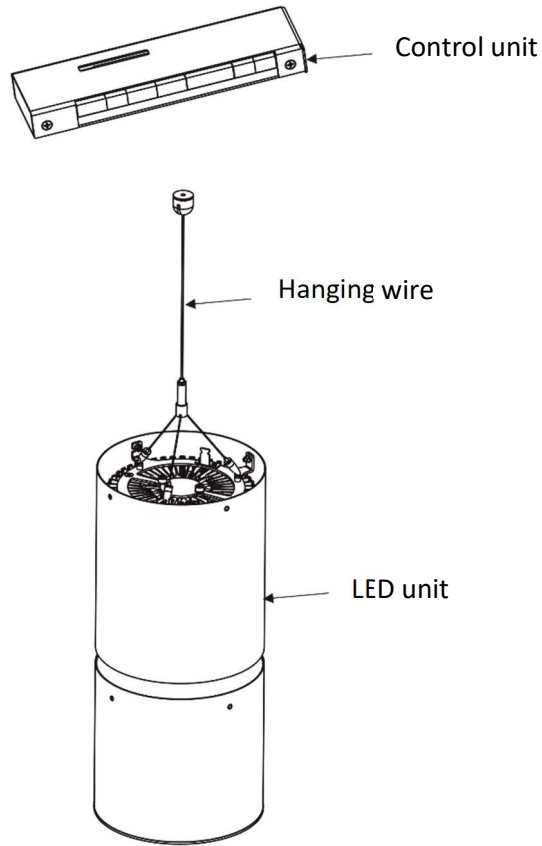

3. Installation

Always switch off power supply of the control unit before connecting or disconnecting the control unit or the light unit.

1. Fasten the control unit (1) on the ceiling by means of two holes in the control unit housing.

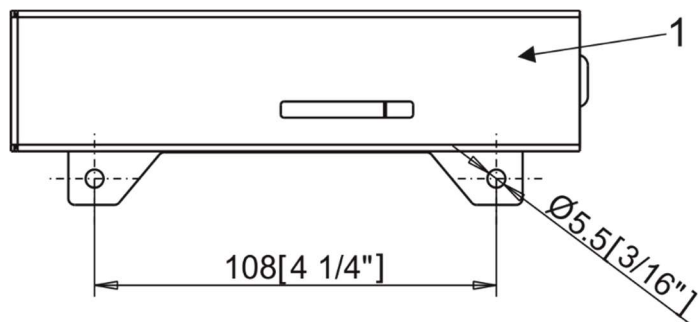

Ambiane XP56 Pendant Remote

2. Fasten the ceiling plate M6i (3) to the lower ceiling.
3. Screw the spherical cap (4) with the hanging wire (6) to the ceiling plate M6i (3).
4. Drill the hole (diameter of 8mm) in the lower ceiling for the LED unit supply cable (7). If you wish to have the LED unit supply cable (7) parallel with the hanging wire (6), the distance between the hanging wire and the LED unit supply cable should be 60mm.

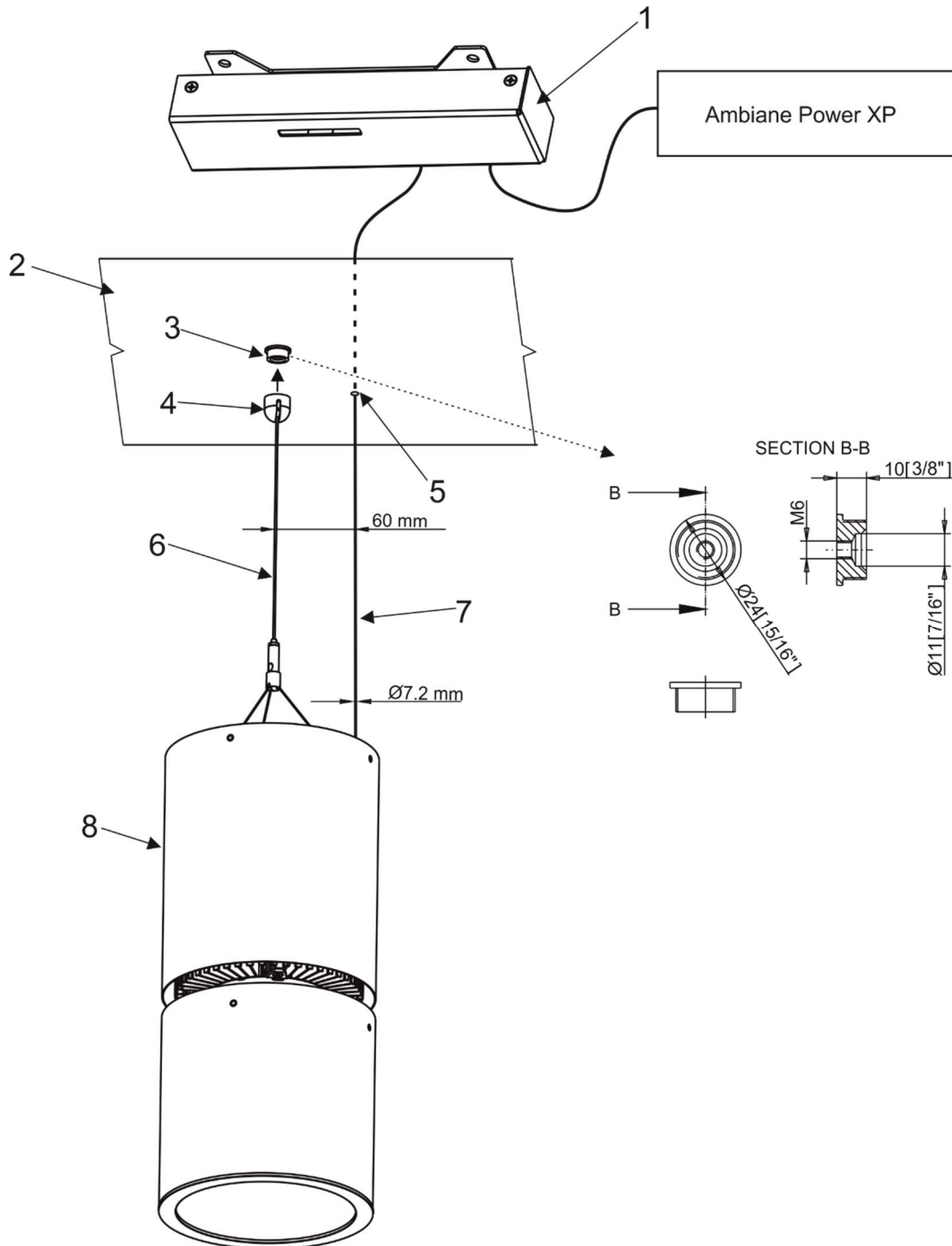

Ambiane XP56 Pendant Remote

5. Install the terminal block (9) on the supply cable connect it to the PCB RB 3729 of the control unit (1).
6. Install the terminal block (10) on the DMX cable and connect it to the PCB RB 3729 of the control unit (1).
7. Install the terminal block (11) on the LED unit cable (7) and connect it to the to the PCB RB 3729 of the control unit (1).
8. Install another terminal blocks on cables according to requirements of current installation.

Example of connection:

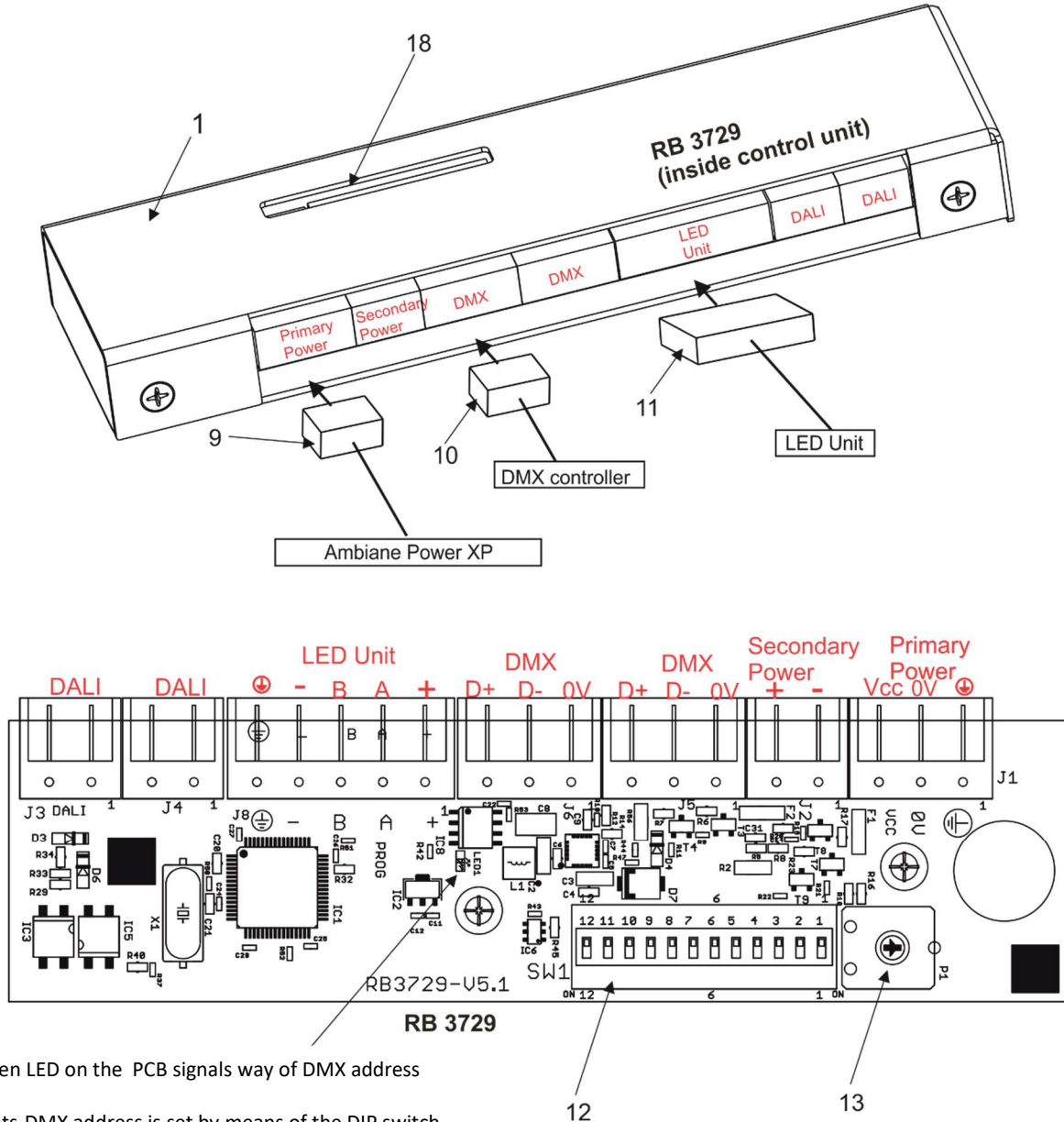

Note: The trimmer (13) allows you to set a light intensity (for secondary power only). This trimmer is accessible by aperture (18) in the cover of the control unit (1).

LED unit connection

Terminal block	+	A	B	-	⊕
Function	LEDs +	Data A	Data B	LEDs -	Ground
Colour of wire	Red	White	Blue	Black	Green/yellow

Ambiane XP56 Pendant Remote

DMX connection

D+	0V	D-
Data +	Data ground(shielding)	Data -

0-10V connection

D+	0V	D-
+10V	0V	Not connected

The primary power input serves for a standard power (e.g. Ambiane Power XP).

The secondary power input serves for a backup power (in case that primary power failed).

If both power inputs are under voltage, the primary power has a priority and the secondary power is disabled. In case of primary power loss, the secondary power is enabled.

If the fixture is supplied via the secondary power, the light output of the fixture is a white colour (3200K) and its light intensity can be set by the trimmer (13).

9. Set the DIP switch (12) according to your operation mode. This DIP switch is accessible by aperture (18) in the cover of the control unit (1).

The fixture can be controlled by one of the following methods: DMX 512

DALI

0-10V (PW or TD version only)

The fixture is equipped with two DMX and DALI connection blocks (on the PCB RB 3729) for easy connection to a DMX or DALI chain (In/Out method).

10. Set desired position of the LED unit by means of the three hanging wires (17). If you need to pull the hanging wire (17) out of the supply unit, you have to press and hold the part (21) of the wire lock.

If the the LED unit supply cable (7) is too long, make a "loop" and fasten it to the holder (18) using a cable binder (19).

Ambiane XP56 Pendant Remote

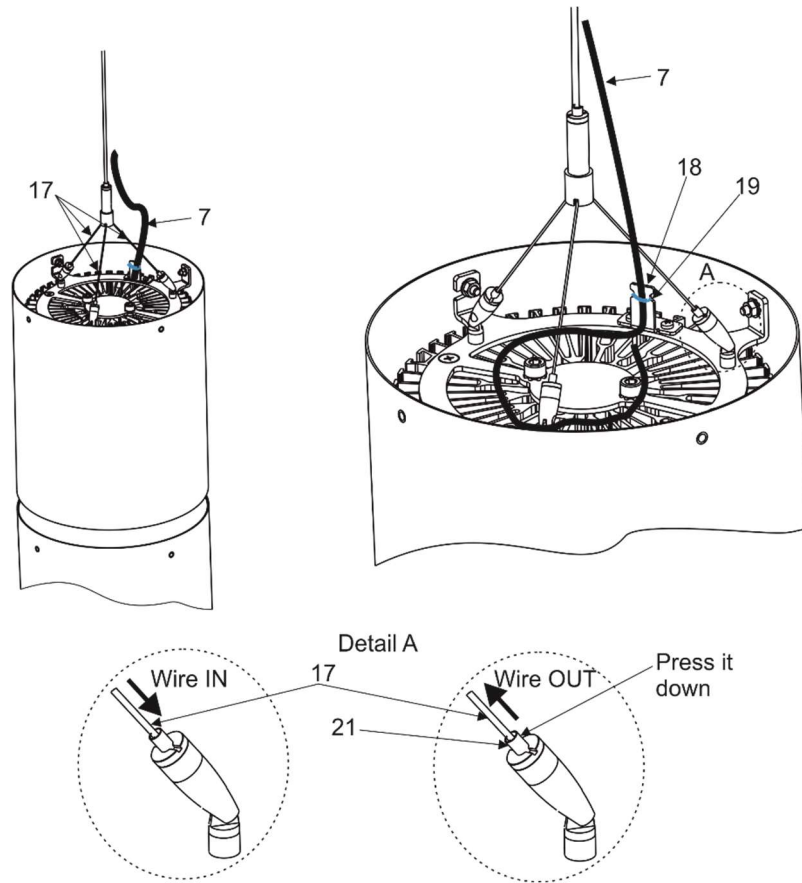

3.1. DMX and DALI address setting and control

The DIP switch on the control PCB, allows you to set DMX address, run a test light and switch the fixture to the update mode in case of software update.

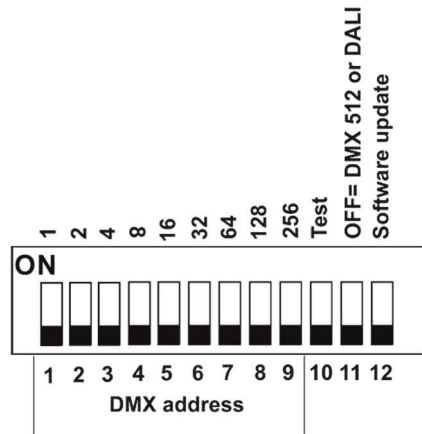

- DIP 10 - if switched to ON=test light (the fixture lights at 3200K (RGBW, TD version))
- DIP 11 - has to be switched to OFF position to receive DMX 512 or DALI, ON position= 0-10V
- DIP 12 - change from OFF to ON position switches the fixture to the update mode.

DMX control

The DMX start address, is the first channel used to receive instructions from the DMX controller. The address may be any channel from 1 to 509. DMX address can be set either by DIP switch or by RDM. DMX address set by RDM overwrites address set by DIP switch and vice versa. The green LED on PCB signals way of DMX address setting:
LED lights-DMX address is set by means of the DIP switch.

Ambiane XP56 Pendant Remote

LED does not light- DMX address is set by means of RDM.

The DIP 11 has to be set to OFF position.

Example of DMX addresses:

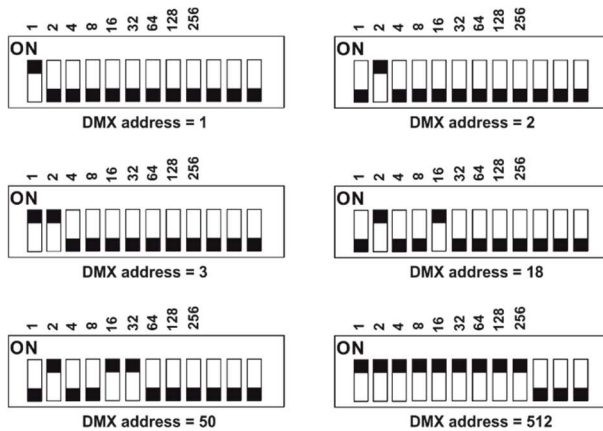

DALI control

Addressing of the fixture has to be made by means of an external DALI controller. The external DALI controller has to send activating command (8=ON) if you need to start the permanent control of the fixture (fixture will not respond to DMX commands) and deactivating command (0=OFF) to stop the control of the fixture.

DIP 11 has to be set in OFF position.

Note: If DIP 11=OFF (fixture is controlled by DMX or DALI), the first coming command switches the fixture to the corresponding operation mode (DMX operation by a DMX command, DALI operation by a DALI command). E.g. the fixture stays in a DALI operation and coming DMX command switches the fixture to DMX operation. Next command is a DALI command and switches the fixture to the DALI operation etc. If you need the permanent DALI operation, you have to send a DALI command 8 to the fixture.

3.2 0-10V control

DIP 11 has to be set in ON position. 0-10V operation has priority to DALI commands. The option is applicable for the Ambiane XP56 Pendant Remote PW and the Ambiane XP56 Pendant Remote TD only.

4. RDM

This fixture supports RDM operation. RDM (Remote Device Management) is a bi-directional communication protocol for use in DM X512 control systems, it is the new open standard for DMX512 device configuration and status monitoring.

RDM allows you to set a DMX address, select DMX mode, readout software version of the fixture. It is also used for fixture software update by means of the Robe Uploader

5. DMX protocol

Version 1.0

Variant RGBW, version 1.0

Mode 1 Channel	Mode 2 Channel	Mode 3 Channel	DMX value	Function	Type of control
1	1	1	0-255	Red Red LEDs saturation control (0-100%)	proportional
-	-	2	0-255	Red Fine Red LEDs saturation control (min.-max.)	proportional
2	2	3	0-255	Green Green LEDs saturation control (0-100%)	proportional
-	-	4	0-255	Green Fine Green LEDs saturation control (min.-max.)	proportional
3	3	5	0-255	Blue Blue LEDs saturation control (0-100%)	proportional
-	-	6	0-255	Blue Fine Blue LEDs saturation control (min.-max.)	proportional
4	4	7	0-255	White White LEDs saturation control (0-100%)	proportional
-	-	8	0-255	White Fine White LEDs saturation control (min.-max.)	proportional
-	5	9	0-255	Dimmer Light intensity coarse (0 -100%)	proportional
-	6	10	0-255	Dimmer Fine Light intensity fine (min.-max.)	proportional

DMX mode has to be set by RDM.

Variant TW, version 1.0

Mode 1 Channel	DMX value	Function	Type of control
1	0-255	White colour selection White from Warm-->Cool	proportional
2	0-255	Dimmer coarse Light intensity coarse (0-100%)	proportional
3	0-255	Dimmer fine Light intensity fine (0-100%)	proportional

Variant PW, TD version 1.0

Mode 1 Channel	DMX value	Function	Type of control
1	0-255	Dimmer coarse Light intensity coarse (0-100%)	proportional
2	0-255	Dimmer fine Light intensity fine (min.-max.)	proportional

DMX mode has to be set by RDM.

6. Technical specifications

Input voltage:	48V DC
Max. power consumption:	150W
Light source:	High Power LED module
Beam angle:	20°, 30°,45°, 60°
Projected Lumen Maintenance:	60.000 hrs (L70 @ 25 °C / 77 °F)
Colour Variants:	RGBW (W - 2700K or 4000K), PureWhite, Tunable White, Tungsten Dim
Colour Temperature of White:	PW 2700 K or 4000K, TW 2700 - 4000K
Control:	DMX, DALI , RDM, 0-10V
Settings/Addressing:	DIP Switch, RDM
DMX channels:	4 (Mode 1), 6 (Mode 2), 10 (Mode 3)
Operating ambient temp. range:	-20 °C / +40 °C (-4 °F / +104 °F)
Operating Temperature (LED unit):	+75 °C @ Ambient +40 °C (167 °F @ Ambient 104 °F)
Total heat dissipation:	512 BTU/h (calculated)
Cooling:	convection
Housing:	High Pressure Die-Cast Aluminium Body
Weight (without control unit) :	
Ambiane XP56 Pendant Remote 20°	9.3 kg/ 20.5 lbs
Ambiane XP56 Pendant Remote 30°	9.3 kg/ 20.5 lbs
Ambiane XP56 Pendant Remote 45°	9 kg/ 19.84 lbs
Ambiane XP56 Pendant Remote 60°	8.9 kg/ 19.62 lbs
Mounting Method:	pendant with 1 adjustable hanging wire
IC rating:	non-IC rated
Power/DMX/DALI connection:	terminal blocks (Phoenix Contact PT 4-WE/3 / BCH-500HS-3GN/ BCH-500HS-2GY)
LED unit connection:	terminal block (Phoenix Contact BCH-500HS-5GN)
Protection factor:	IP 2X

Ambiane XP56 Pendant Remote

Dimensions

mm [inch]

Ambiane XP56 Pendant Remote 20°
Ambiane XP56 Pendant Remote 30°

Ambiane XP56 Pendant Remote 45°

Ambiane XP56 Pendant Remote 60°

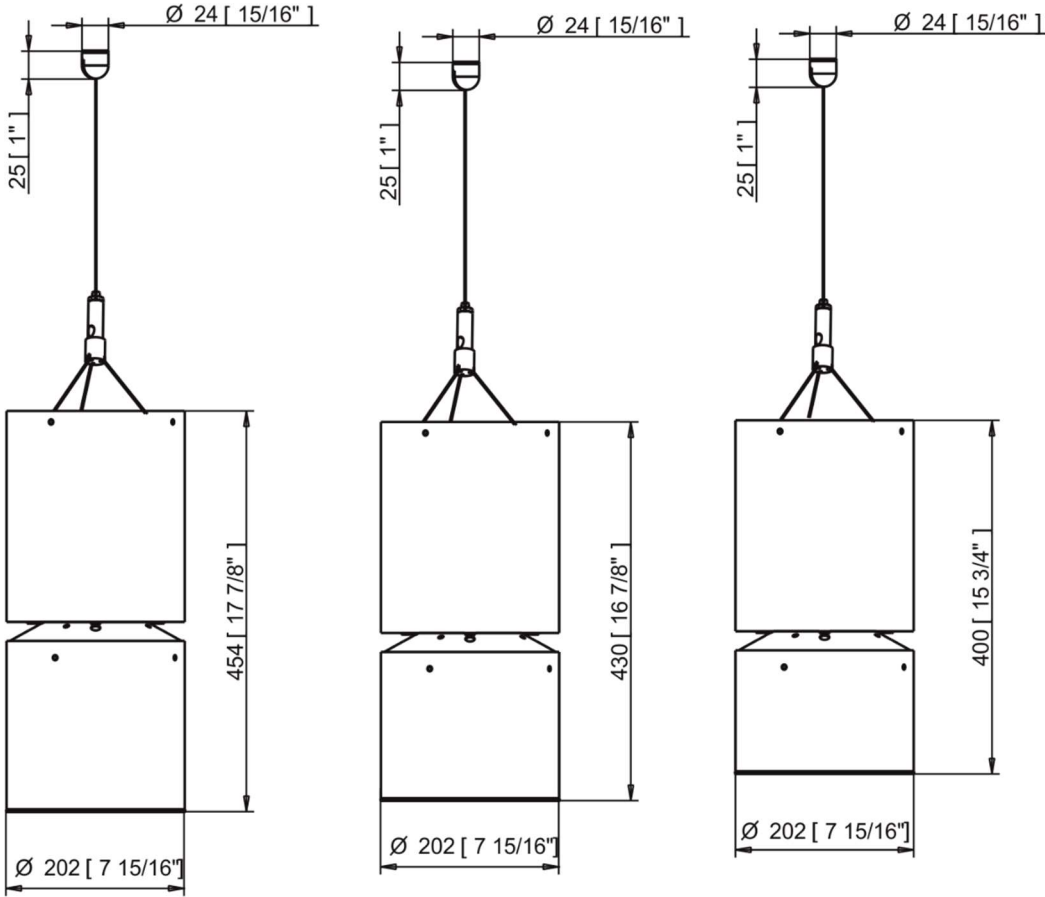

Control unit

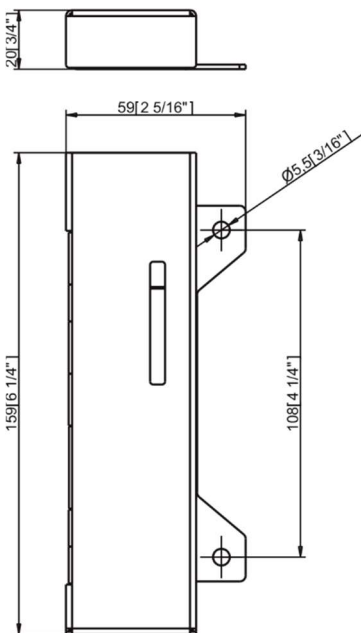

Included items

- 1 x Ambiane XP56 Pendant Remote
- 1 x Control unit
- 1 x Set of cable connectors
- 1 x User manual

Option items

- Ambiane Power XP (P/N 10063710)
- Ambiane Power XP-G (CE) (P/N 10063950)
- Ambiane Power XP-G (US) (P/N 10064011)

7. Cleaning and maintenance

Disconnect from the mains before starting any maintenance or cleaning work

Keep the fixture clean, especially light source and the ribbed heat sink.
Maintenance and service operations are only to be carried out by a qualified person.
Should you need any spare parts, please use ROBE OEM parts.

7.1 Software update

The fixture has to be connected to power during software update.

Software update by means of the DSU file.

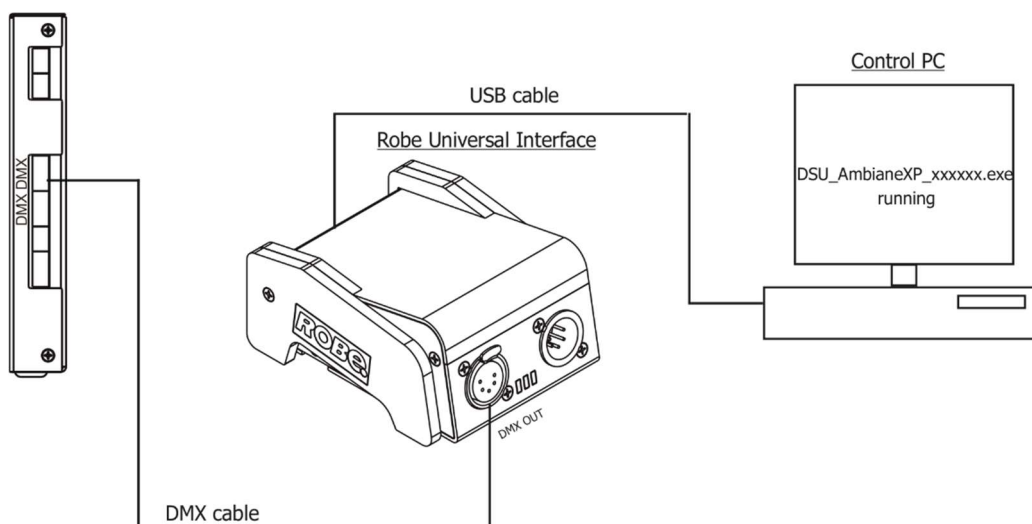

The following items are required in order to update software:

- PC running Windows or Linux or macOS
- DSU file
- Robe Universal Interface / Robe Universal interface WTX.

To update software in the fixture:

1. DSU file is available from the ROBE web site at <https://www.robe.cz/architectural/download/#software-updates>.
File with extension zip is intended for Windows (used and tested from XP56 to W10 on 32/64bit systems).

Ambiane XP56 Pendant Remote

File with extension tbz is intended for Linux (used and tested on Debian and Ubuntu 32/64bit).

File with extension dmg is intended for macOS (used and tested on OSX up to Sierra) XQuartz required, install it from <https://www.xquartz.org/>

Save the download file to a folder on your computer.

In case that you use windows, extract files in the zip file (e.g. DSU_AmbianeXP56_18051040.zip)

2. Switch the fixture off and disconnect the fixture from DMX controller (If you use DALI control, switch off the DALI controller).
3. If you use the flash cable RS232/DMX, connect a serial port of your computer with DMX input of the fixture by means of this cable (probably you will need some USB to RS 232 converter if your computer has USB ports only).
If you use the Robe Universal Interface, connect a USB port of your computer with the Robe Universal Interface by means of the USB cable and DMX input of the fixture with the DMX output of the Robe Universal Interface via a DMX cable.
4. Switch the fixture on and switch it to the update mode (switch the DIP 12 from OFF to ON position).
We recommend to cancel all running programs on your computer before starting the software uploader.
5. Double-click the software uploader file (e.g. DSU_AmbianeXP56_18051040.exe) in the extracted files. The Software Uploader program will start running.

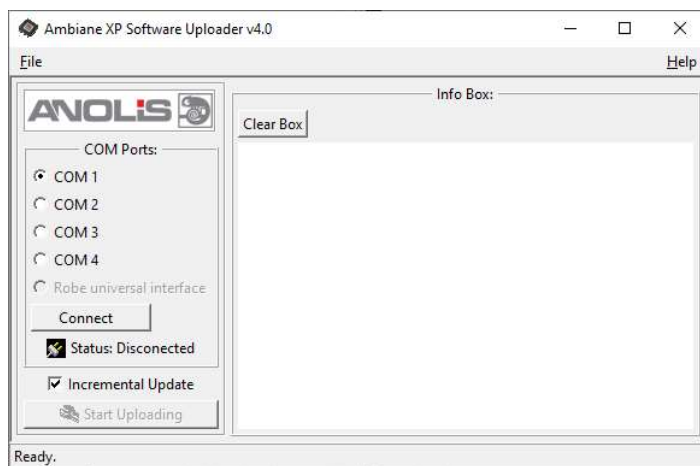

6. Select correct "COM " number if you use a Flash cable RS232/DMX or select "Robe Universal Interface " if you use the Robe Universal Interface/Robe Universal Interface WTX and then click on the "Connect" button.
7. If the connection is OK, click the "Start Uploading" button to start software uploading. It will take several minutes to perform software update.
If the option "Incremental Update" is not checked, all processors will be updated (including processors with the same software version).
If you wish to update only processors with new version of software, check the "Incremental Update box".
Avoid interrupting the process. Update status is being displayed in the "Info Box" window.
When the update is finished, the line with the text "Fixture is successfully updated" will appear in this window.
8. Switch the fixture off and set the DIP 12 to OFF position.

In case upload process is interrupted (e.g. power loss), the fixture stays in "Updating mode" and you will have to repeat the software update again.

Software update by means of the Robe Uploader

Another way, how to update software in the fixtures (especially large installation of fixtures) is to use the ROBE Uploader. It is a software for automatized software update of Robe and Anolis fixtures. It can take advantage of RDM support.

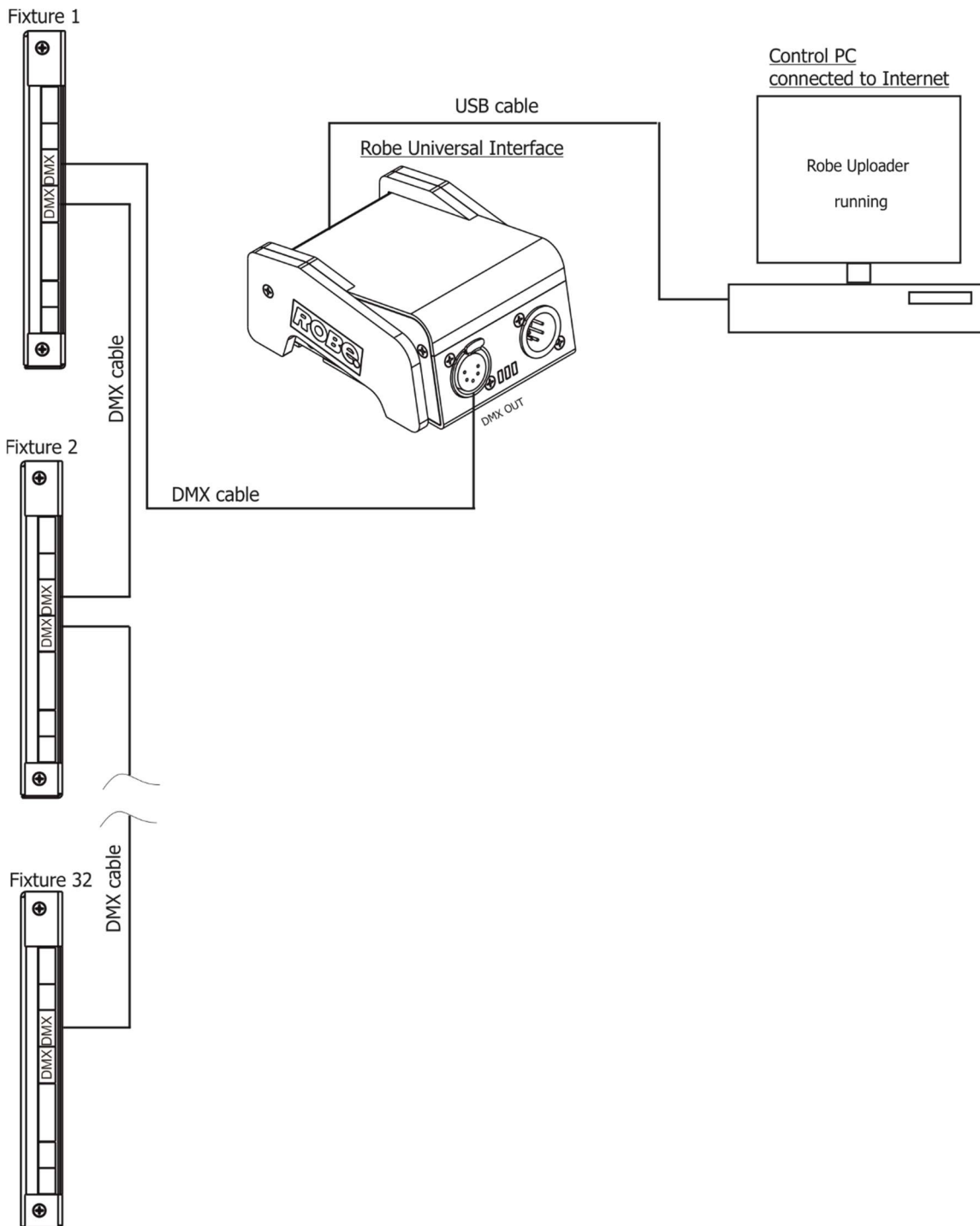

The fixtures have to be connected in a daisy-chain (max. 32 fixtures) and via the Robe Universal Interface/Robe Universal Interface WTX and a USB cable connected to the control PC with the Robe Uploader running. The fixtures have to be connected to power. The control PC should be connected to the Internet.

Ambiane XP56 Pendant Remote

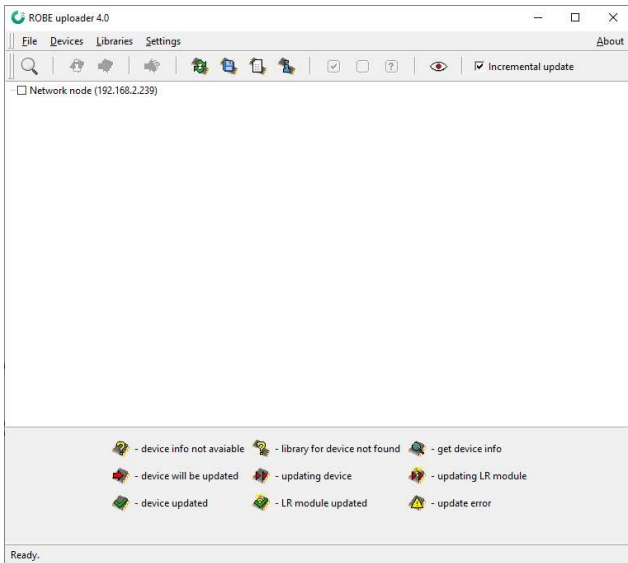

The Robe Uploader software and user manual is available at :
<https://www.robe.cz/robe-uploader/>

If you do the software update by means of the Robe Uploader, switching fixtures to the update mode (and from the update mode) is made automatically, without need to switch the DIP 12 to ON position (update mode).

Note: The Robe Uploader software cannot be used if fixtures are connected by means of DALI connection.

7.2 Disposing of the product

To preserve the environment please dispose or recycle this product at the end of its life according to the local regulations and codes.

Specifications are subject to change without notice

March 16, 2021

Made in CZECH REPUBLIC by ROBE LIGHTING s.r.o. Palackeho 416/20 CZ 75701 Valasske Mezirici