

User manual

Ambiane AP (RGBW, RGBA, TD, PW, TW)

The unit generates light by means of high power LEDs. The unit was designed for indoor use only.

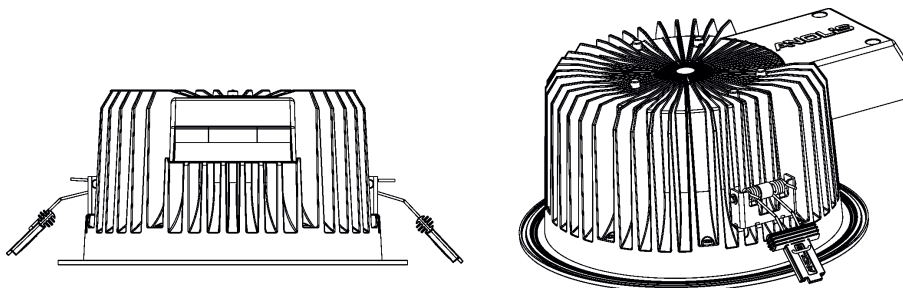

1. Attention

The unit must be installed by a qualified electrician in accordance with all national and local electrical and construction codes and regulations. The unit was designed for indoor use only.

Avoid looking directly into the LED light beam at close range!

Do not install the unit near highly inflammable liquids or materials.

Do not allow anything to rest on the unit.

Do not install the unit near an open flame.

Do not install the unit in dirty, dusty or badly ventilated location.

Sufficient air accessing to the housing of the unit has to be ensured, there must not be any heat or anti-noise insulation within a 0.6m x 0.6m area around the unit (non-IC rated fixture).

Immunity of the equipment is designed for electromagnetic environments E1, E2, E3 according to the standard EN55103-2 ed.2 Electromagnetic compatibility. Product family standard for audio, video, audiovisual and entertainment lighting control apparatus for professional use. Part 2: Immunity.

The product (covers and cables) must not be exposed to a high frequency electromagnetic field higher than 3V/m.

The installation company should check levels of possible interferences above the tested levels E1, E2, E3 given by this standard (e.g. transmitters in surrounding area) before installing the equipment. Emission of the equipment complies with the standard EN55032 Electromagnetic compatibility of multimedia equipment – Emission Requirements according to class B.



Suitable for fastening on non-flammable surfaces only



Unsuitable for covering by heat insulation material

Always switch off power supply of the unit before connecting or disconnecting the unit

2. Installation

1. Prepare a circular opening in the lower ceiling (1) as shown in the picture below.
2. Insert the Ambiane AP unit into the opening. Fasten the Ambiane AP by means of two spring fasteners (2) to the opening.

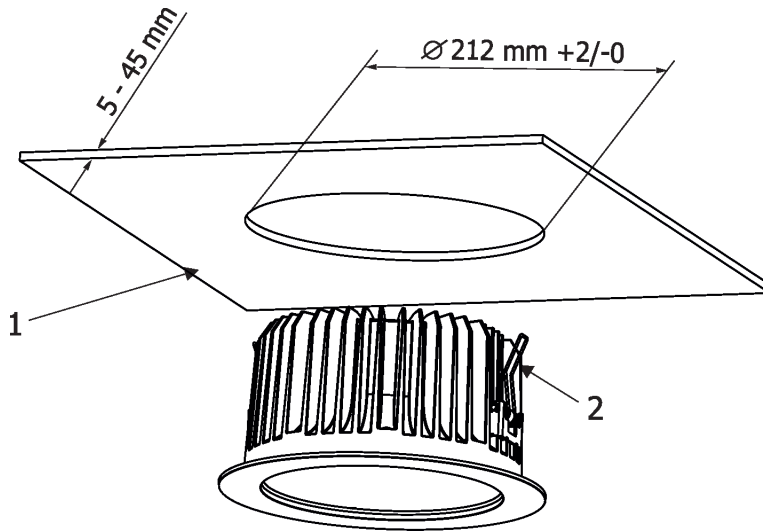

3. Connect needed cables to the Ambiane AP. Connection blocks (4) are placed on the PCB RB 3727 (3). The PCB is under plastic cover (5) which is fastened by means of two screws (6).

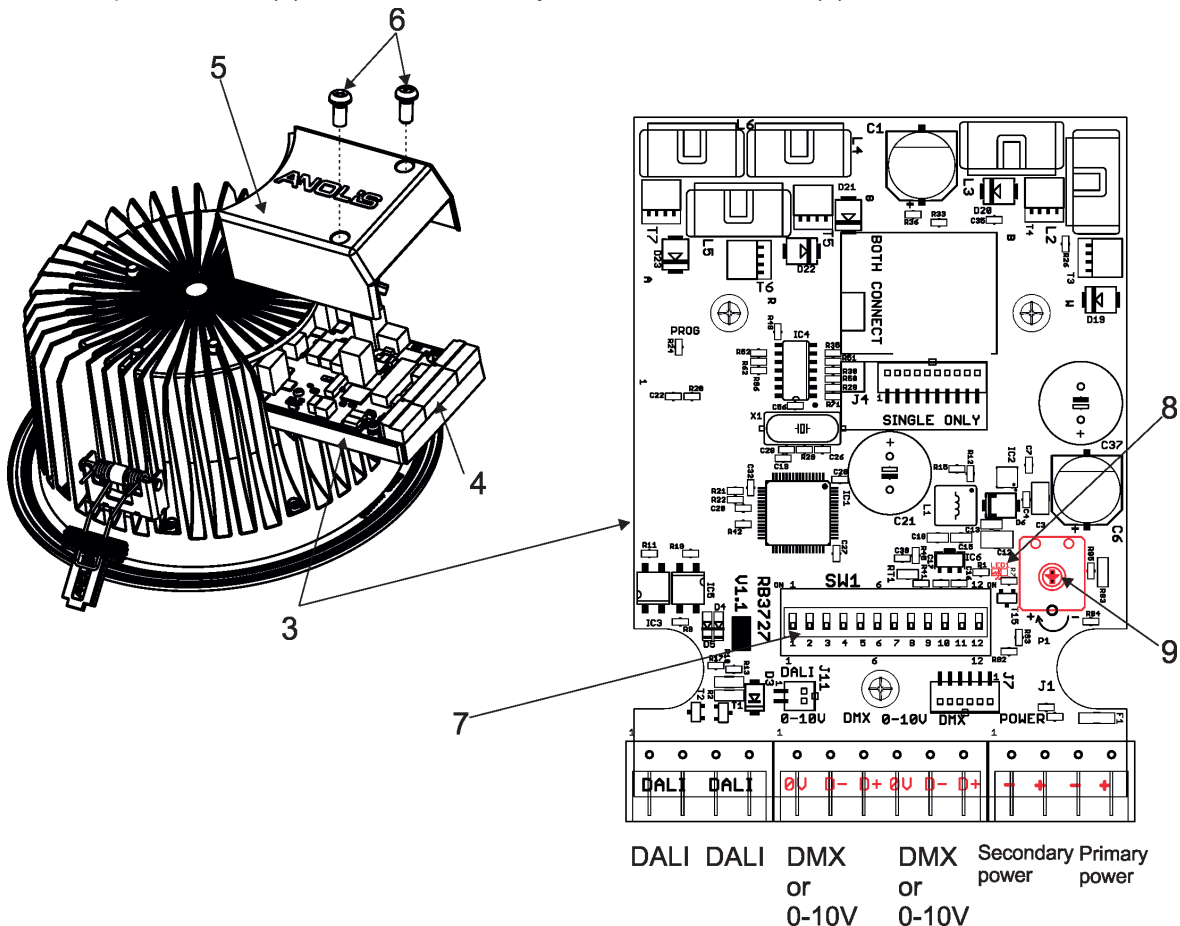

The primary power input serves for a standard power (e.g. Power Supply for Ambiane AP).
 The secondary power input serves for a backup power(in case that primary power failed).
 If both power inputs are under voltage, the primary power has a priority and the secondary power is disabled.
 In case of primary power loss, the secondary power is enabled.

If the Ambiane AP is supplied via the secondary power, the light intensity can be set by the trimmer (9).

The Ambiane AP can be controlled by one of the following methods: DMX 512

- DALI
- 0 - 10V (Ambiane AP PW, Ambiane AP TD only)

The Ambiane AP is equipped with two DMX and DALI connection blocks for easy connection to DMX or DALI chain (In/Out method).

DMX connection

PCB	Function
0V -	Shield
D+	Signal (+)
D-	Signal (-)

0-10V connection

PCB	Function
0V	0V
D+	+10V

Power connection

PCB	Function
+	Power +
-	Power -

Recommended diameters of conductors with respect to distance between Ambiane AP and power supply unit (Ambiane Power AP).

Distance/cable length	50 m	100 m
Diameters of conductors	0.5 mm ²	1 mm ²

3. DMX and DALI address setting and control

The DIP switch (7), located next to the connection blocks, allows you to run a test light and switch the Ambiane AP to the update mode in case of software update.

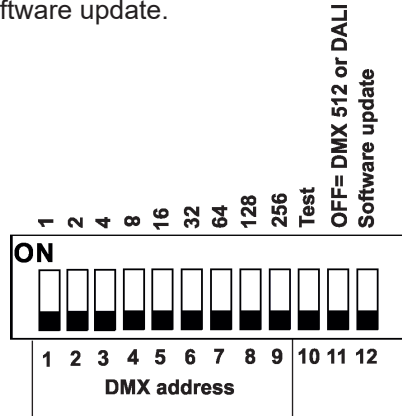

DIP 10 - if switched to ON=test light (3200K for RGBW and TW version)

DIP 11 - selection of fixture control: OFF=DMX 512 or DALI, ON=0-10V

DIP 12 - change from OFF to ON position switches the Ambiane AP to the update mode (switching to the update mode is not necessary if the Robe Uploader is used for Ambiane AP update).

DMX control

The DMX start address, is the first channel used to receive instructions from the DMX controller. The address may be any channel from 1 to 509. DMX address can be set either by DIP switch or by RDM. DMX address set by RDM overwrites address set by DIP switch and vice versa. The green LED (8) on the PCB signals way of DMX address setting:

LED lights-DMX address is set by means of the DIP switch.

LED does not light- DMX address is set by means of RDM.

DIP 11 has to be set in OFF position.

Example of DMX addresses:

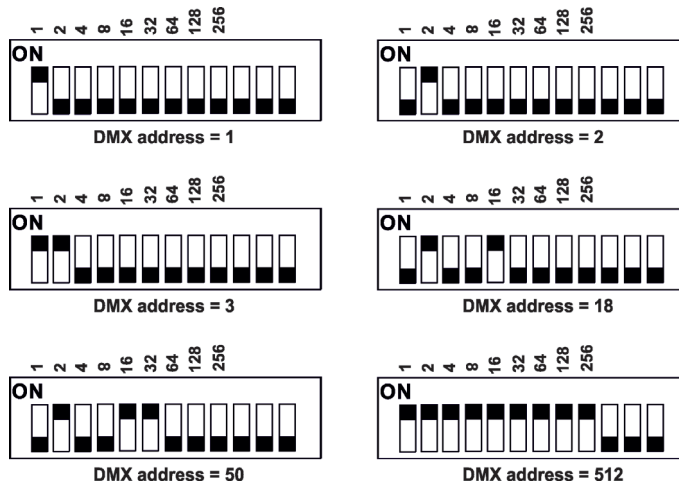

DALI control

Addressing of the Ambiane AP is made by means of an external DALI controller. The external DALI controller has to send activating command (8=ON) if you need to start the permanent control of the Ambiane AP (Ambiane

AP will not respond to DMX commands) and deactivating command (0=OFF) to stop control of the Ambiane AP. DIP 11 has to be set in OFF position.

Note: If DIP 11=OFF (Ambiane AP is controlled by DMX or DALI), the first coming command switches the Ambiane AP to the corresponding operation mode (DMX operation by a DMX command, DALI operation by a DALI command). E.g. the Ambiane AP stays in a DALI operation and coming DMX command switches the Ambiane AP to DMX operation. Next command is a DALI command and switches the Ambiane AP to the DALI operation etc. If you need the permanent DALI operation, you have to send a DALI command 8 to the Ambiane AP.

0-10V control

DIP 11 has to be set in ON position. 0-10V operation has priority to DALI commands. The option is applicable for Ambiane AP PW and Ambiane AP TD only.

4. RDM

This Ambiane AP supports RDM operation. RDM (Remote Device Management) is a bi-directional communication protocol for use in DM X512 control systems, it is the new open standard for DMX512 device configuration and status monitoring.

RDM allows you to set some options as DMX address, select DMX mode and readout software version of the Ambiane AP etc.

Via RDM you can also set behaviour of the fixture in case of loss of DMX signal. For this purpose serve the following two options:

DMX hold

Value On (0) - the fixture keeps last received DMX values in case of DMX loss (default setting).

Value Off (1) - it activates the option " DMX lost". To set the option "DMX hold" to Off, you have to send a value 1 via RDM.

DMX lost

The option is active only if the option "DMX hold" is set Off.

Value On (0) - the fixture lights at max. light output in case of DMX loss (default setting).

Value Off (1) - The light output of the fixture is closed in case of DMX loss. To set the option "DMX lost" to Off, you have to send a value 1 at RDM.

RDM model ID for the Ambiane AP is 0x0114.

Parameter ID	Discovery command	SET command	GET command
DISC_UNIQUE_BRANCH	*		
DISC_MUTE	*		
DISC_UN_MUTE	*		
DEVICE_INFO			*
SUPPORTED_PARAMETERS			*
SOFTWARE_VERSION_LABEL			*
DMX_START_ADDRESS		*	*
IDENTIFY_DEVICE		*	*
DEVICE_MODEL_DESCRIPTION			*
MANUFACTURER_LABEL			*
DEVICE_LABEL		*	*
SENSOR_DEFINITION			*
SENSOR_VALUE			*
RESET_DEVICE		*	
DMX_PERSONALITY		*	*
DMX_PERSONALITY_DESCRIPTION			*
SENSOR_VALUE		*	*
SENSOR DEFINITION			*

5. Anti-glare ring installation

Insert the anti-glare ring (1) into the Ambiane AP until three locks (2) snap into slots (3).

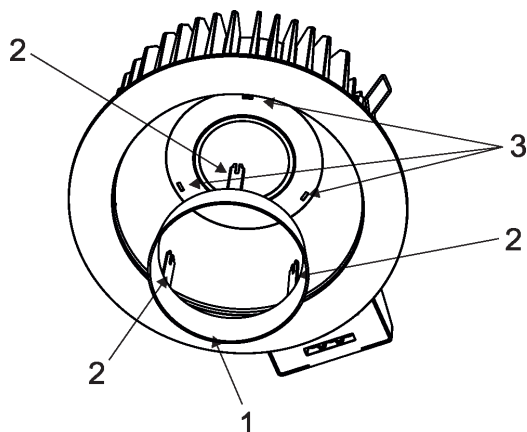

6. Adapter ring installation

1. Remove both spring fasteners (2) by unscrewing the four screws M4x10 (1).
2. Slide the adapter ring (4) onto the housing of the Ambiane AP. Screw the new fasteners (3) on the housing. Use original screws M4x10 (1).

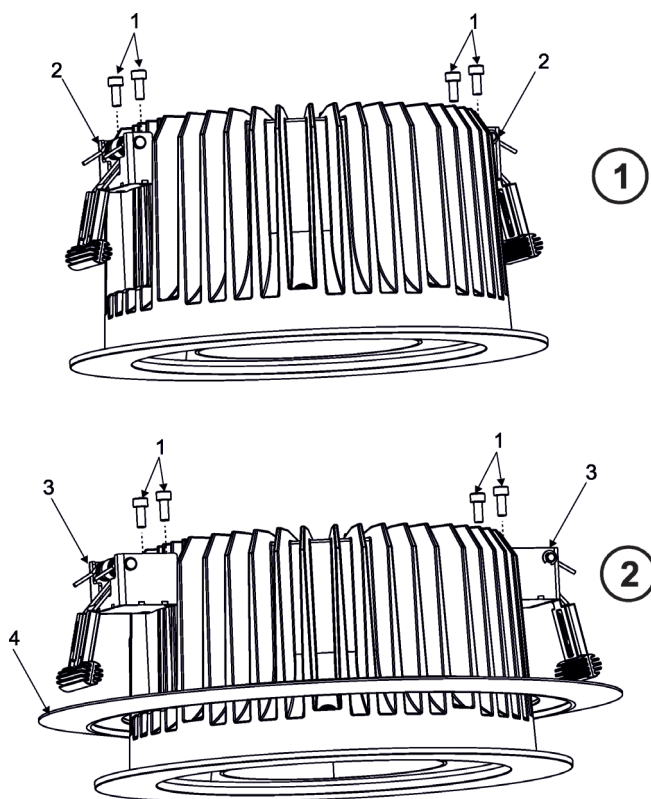

7. DMX protocols

Ambiane AP RGBW , Ambiane AP RGBA

Version 1.2

Mode 1 Channel	Mode 2 Channe	Mode 3 Channe	Mode 4 Channe	Mode 5 Channe	Value	Function	Type of control
1	1	1	-	1	0-255	Red Red LEDs saturation control 0% -->100%	proportional
-	-	2	-	-	0-255	Red Fine Red LEDs saturation control from min. -->max.	proportional
2	2	3	-	2	0-255	Green Green LEDs saturation control 0% -->100%	proportional
-	-	4	-	-	0-255	Green Fine Green LEDs saturation control from min. -->max.	proportional
3	3	5	-	3	0-255	Blue Blue LEDs saturation control 0% -->100%	proportional
-	-	6	-	-	0-255	Blue Fine Blue LEDs saturation control from min. -->max.	proportional
4	-	7	-	4	0-255	White/Amber White (Amber) LEDs saturation control 0% -->100%	proportional
-	-	8	-	-	0-255	White/Amber Fine White(Amber) LEDs saturation control min. -->max.	proportional
-	-	9	1	-	0 1-127 128 129-255	Green White Fine Uncorrected white Minus green --> uncorrected white Uncorrected white (128=default) Uncorrected white --> plus green	step proportional step proportional
-	-	10	2	-	0 1-10 11-20 21-255	Colour temperature correction (CTC) No function (default) Tungsten dimming 3200K Tungsten dimming (3200K) Colour temperature changing 2700K-6500K (21=2700K, 64-3200K, 128=4200K, 192-5600K, 255=6500K)	step step step proportional
-	-	11	3	5	0-255	Dimmer Light intensity coarse 0% -->100%	proportional
-	-	12	-	6	0-255	Dimmer Fine Light intensity from min. -->max.	proportional

Ambiane AP PW, Ambiane AP TD

Version 1.1

Mode 1 Channel	Mode 2 Channel	Value	Function	Type of control
1	1	0-255	Dimmer Light intensity coarse 0% -->100%	proportional
-	2	0-255	Dimmer Fine Light intensity from min. -->max.	proportional

Ambiane AP TW

Version 1.3

Mode 1 Channel	Mode 2 Channel	Mode 2 Channel	Mode 2 Channel	Value	Function	Type of control
1	-	1	-	0-255	White colour selection White from 2700K-->4000K	proportional
-	1	-	1	0-255	Warm White Warm White LEDs saturation control 0% -->100%	proportional
-	2	-	2	0-255	Cool White Cool White LEDs saturation control 0% -->100%	proportional
2	3	2	3	0-255	Dimmer coarse Light intensity coarse 0% -->100%	proportional
-	-	3	4	0-255	Dimmer Fine Light intensity from min. -->max.	proportional

8. Technical specifications

Input voltage:	48V DC
Protection class:	CE:  (Class III)
	ETL: Class 2 or LVLE
Max. power consumption:	40W
Beam angle:	67°, 80° with anti-glare ring
Colour temperature:	
Ambiane AP PW	2700K, 4000K
Ambiane AP TW	2700K - 4000K
Ambiane AP TD	3200K
Control:	
Ambiane AP RGBW, Ambiane AP TW	DMX, DALI, RDM compatible
Ambiane AP PW, Ambiane AP TD	DMX, DALI, 0-10V, RDM compatible
DMX channels:	
Ambiane AP RGBW	4 (Mode 1), 3 (Mode 2), 12 (Mode 3), 3 (Mode 4), 6 (Mode 5)
Ambiane AP PW, Ambiane TD	1 (Mode 1), 2 (Mode 2)
Ambiane AP TW	2 (Mode 1), 3 (Mode 2)
Typical Lumen maintenance:	70% @ 50,000 hours
Led life expectancy:	minimum 50,000 hours
Operating ambient temp. range:	-20°C/+45°C (-4F/+113F)
Operating temperature:	75°C @ Ambient +35°C (167°F @ Ambient +95°F)
Total heat dissipation:	136 BTU/h (calculated)
Cooling :	convection
Housing:	alluminium
Weight:	1.9 kg (4.19 lbs)
Installation method:	via two spring fasteners
IC rating:	non-IC rated
Power/DMX/DALI connection:	terminal blocks
Protection factor:	IP 20 (without diffuser glass), IP20/IP54 (with Diffuser Glass)

Ambiane AP without Diffuser Glass

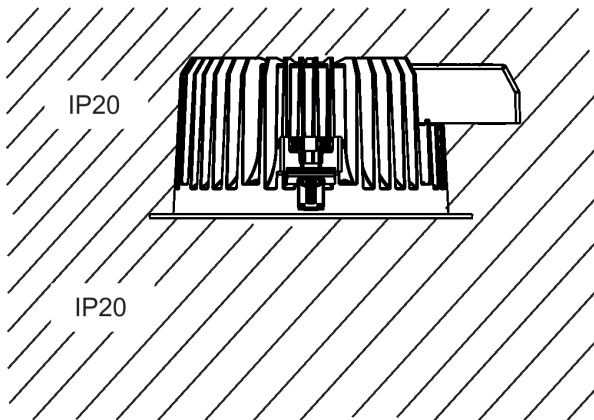

Ambiane AP with Diffuser Glass

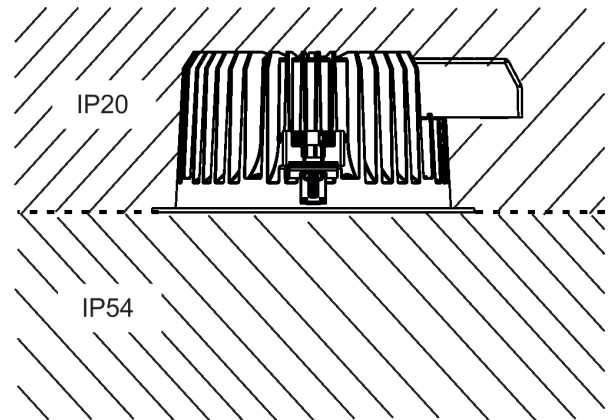

9. Included items

- 1 x Ambiane AP
- 1x Anti-Glare Ring (P/N 10980386)
- 1 x Set of cable connectors
- 1 x User manual

10. Optional Accessories

- Ambiane Power AP (P/N 10063994)
- Anti-Glare Ring (P/N 10980386)
- Adapter Ring (235-255mm) (P/N 10980388)

11. Dimensions

mm [inch]

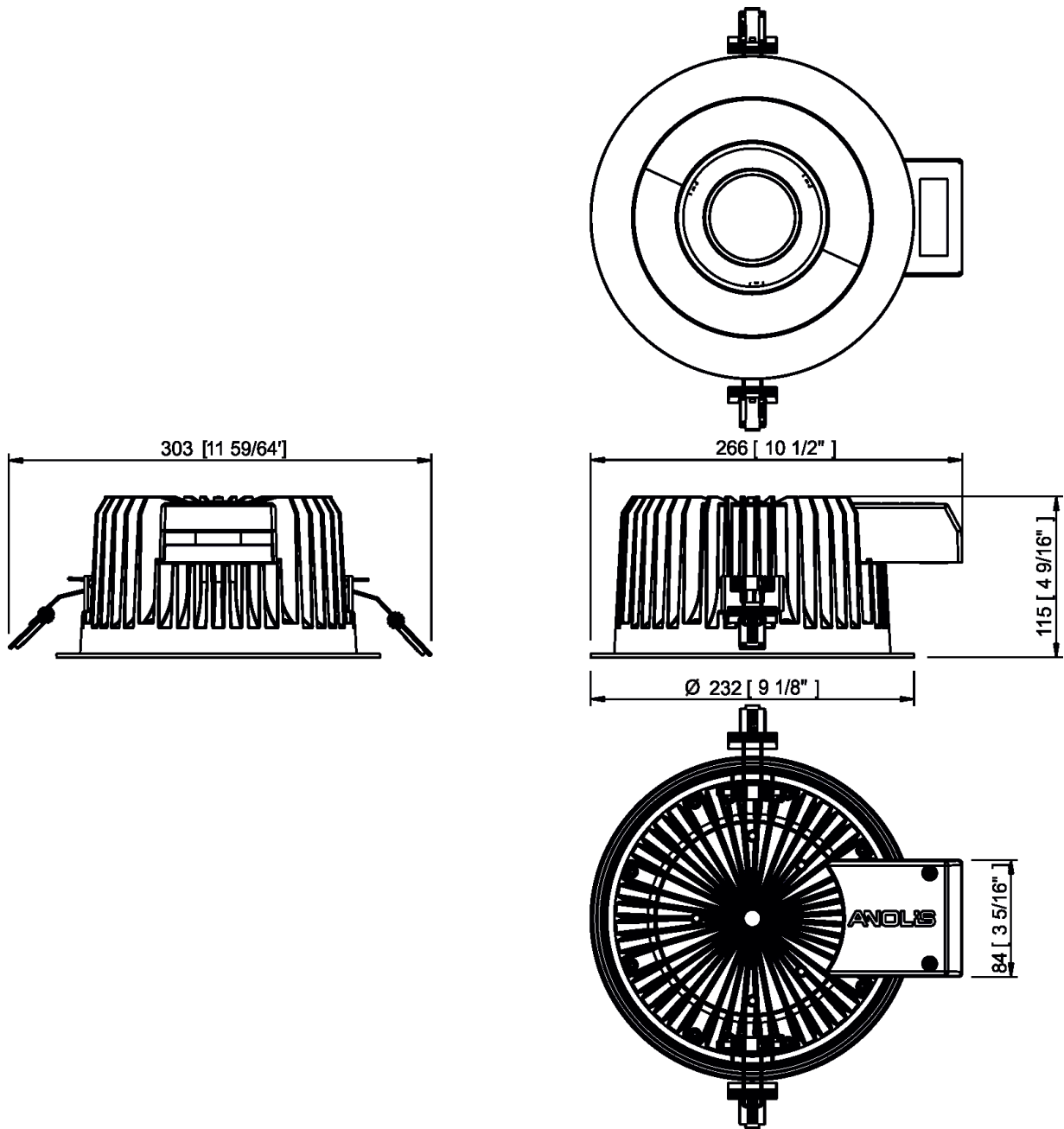

12. Maintenance

Keep the Ambiane AP clean, especially light source and the ribbed housing.

13. Software update

Software update of the fixture can be done by means of the ROBE Uploader. It is a software for automatized software update of Robe and Anolis fixtures. It takes advantage of RDM support.

The fixtures have to be connected in a daisy-chain (max. 32 fixtures) and via the Robe Universal Interface/ Robe Universal Interface WTX and a USB cable connected to the control PC with the Robe Uploader running. The control PC should be connected to the Internet.

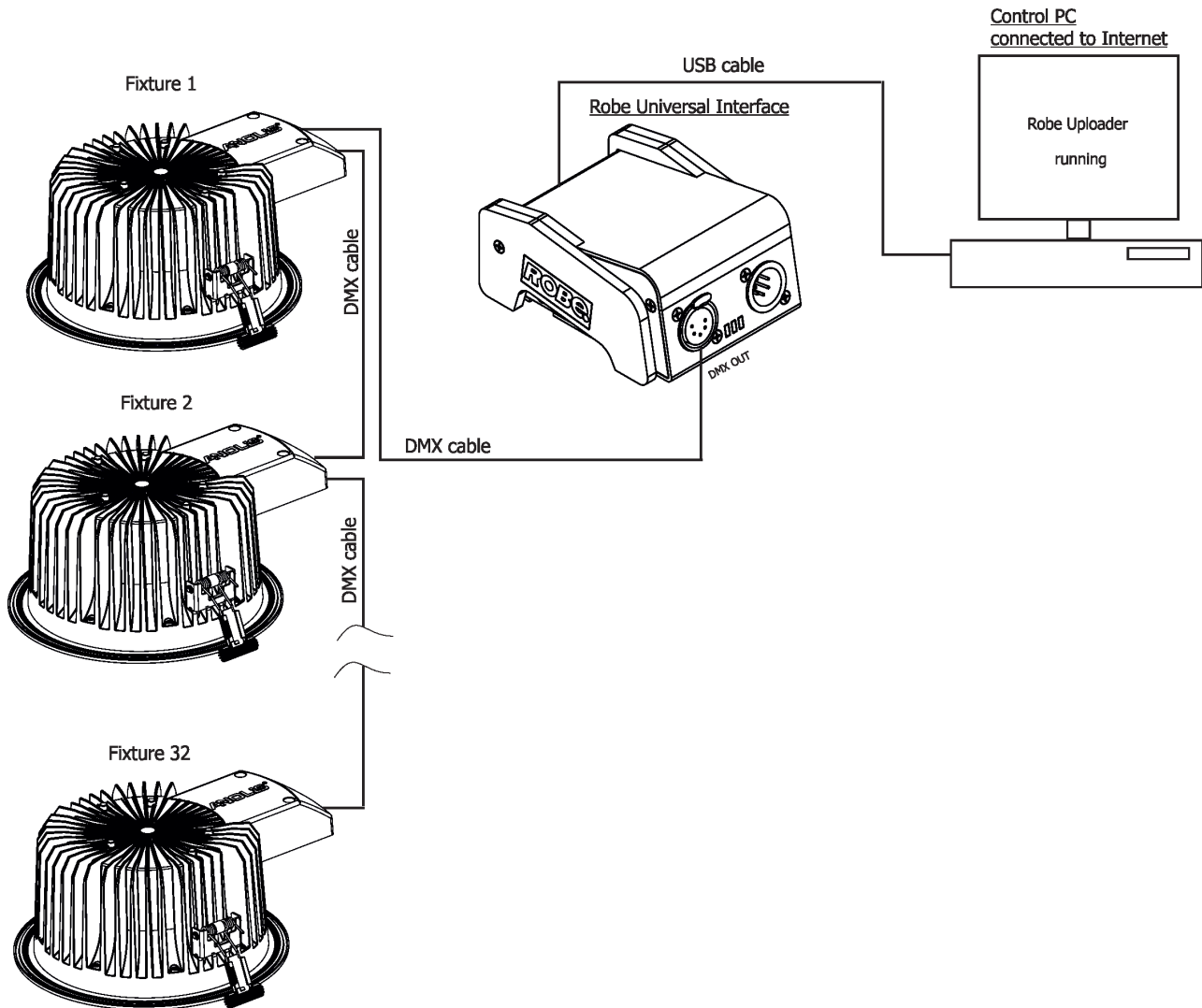

Note:

If you do the software update by means of the Robe Uploader, switching fixtures to the update mode (and from the update mode) is made automatically, without need to switch the DIP 12 to ON position (update mode).

The Robe Uploader software cannot be used if fixtures are connected by means of DALI connection.

The Robe Uploader software and user manual is available at :
<https://www.robe.cz/robe-uploader/>

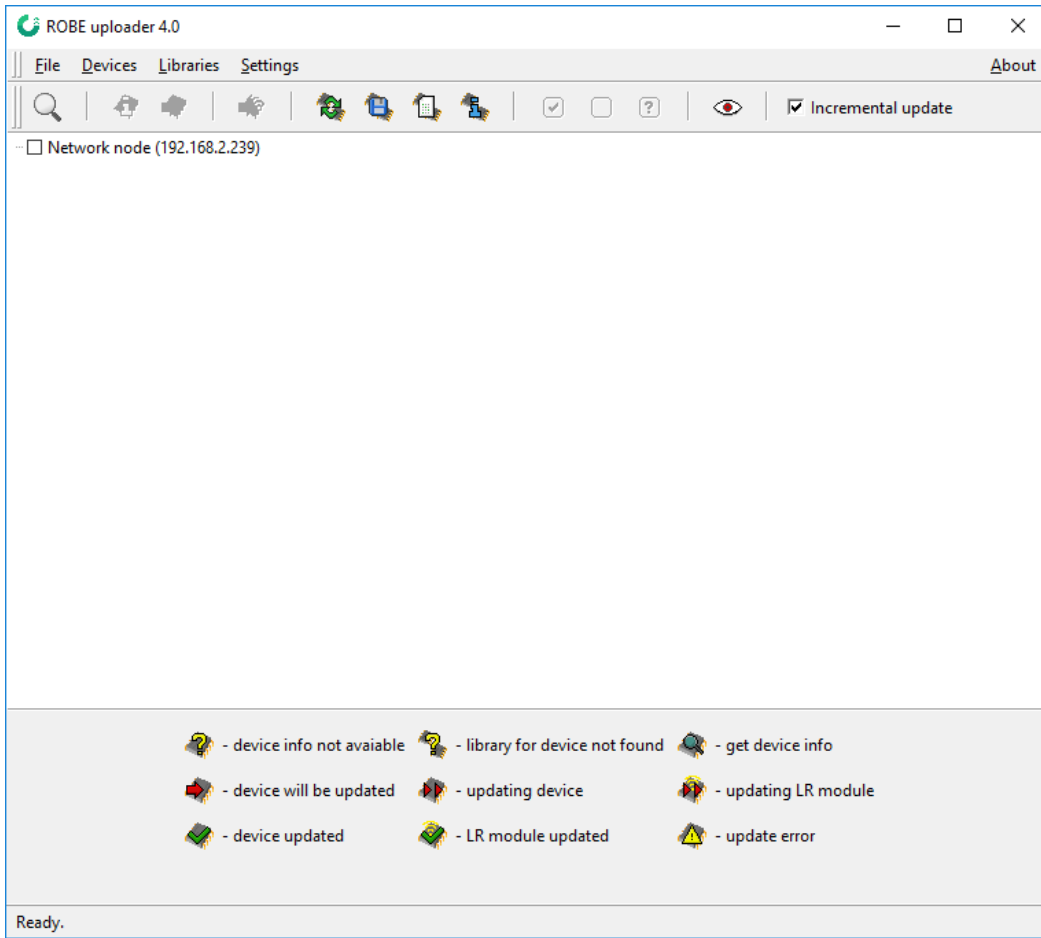

Version 1.9

November 30, 2021

Specifications are subject to change without notice.

Made in CZECH REPUBLIC by ROBE LIGHTING s.r.o. Palackeho 416/20 CZ 75701 Valasske Mezirici