

Ambiane Power Rack Ambiane Power Rack US

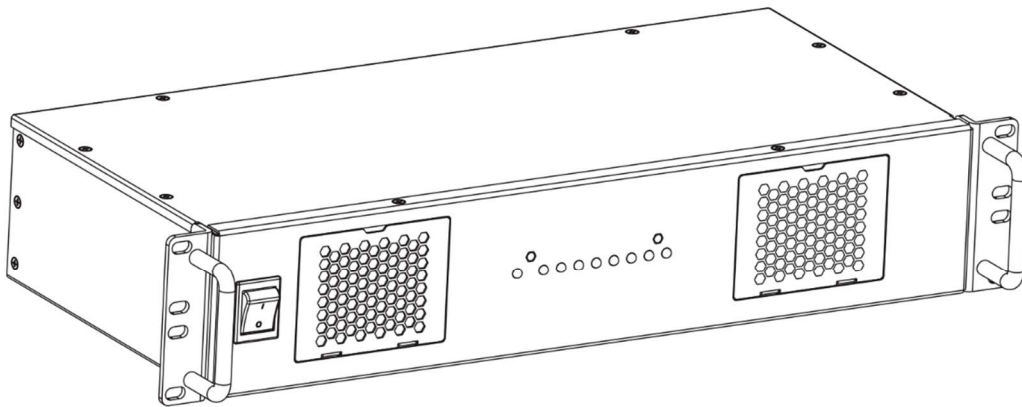

QR code for user manual



Table of contents

| | |
|-----------------------------------|---|
| 1. Attention..... | 3 |
| 2. Fixture exterior view..... | 4 |
| 3. Installation..... | 4 |
| 4. Technical specifications..... | 7 |
| 5. Cleaning and maintenance..... | 8 |
| 5.1 Replacing the fuse..... | 8 |
| 5.2 Replacing air filters..... | 8 |
| 5.3 Disposing of the product..... | 9 |

1. Attention

Dangerous voltage constituting a risk of electric shock is present within this unit.

The unit must be installed by a qualified electrician in accordance with all national and local electrical and construction codes and regulations.

The unit was designed for indoor use only.

Do not install the unit near highly inflammable liquids or materials.

Do not allow anything to rest on the unit.

Do not install the unit near an open flame.

Do not install the unit in dirty, dusty or badly ventilated location.

Do not connect the unit to a dimmer pack.

This fixture falls under protection class I. Therefore this fixture has to be connected to a mains socket outlet with a protective earthing connection.

Disconnect from the mains before starting any maintenance work.

Please consider that unauthorized modifications on the unit are forbidden due to safety reasons!

Resistance of the equipment is designed for electromagnetic environments E1, E2, E3 according to the standard EN55103-2 ed.2 Electromagnetic compatibility. Product family standard for audio, video, audiovisual and entertainment lighting control apparatus for professional use. Part 2: Immunity.

The product (covers and cables) must not be exposed to a high frequency electromagnetic field higher than 3V/m.

The installation company should check levels of possible interferences above the tested levels E1,E2,E3 given by this standard (e.g. transmitters in surrounding area) before installing the equipment.

Emission of the equipment complies with the standard EN55032 Electromagnetic compatibility of multimedia equipment – Emission Requirements according to class B.

2. Fixture exterior view

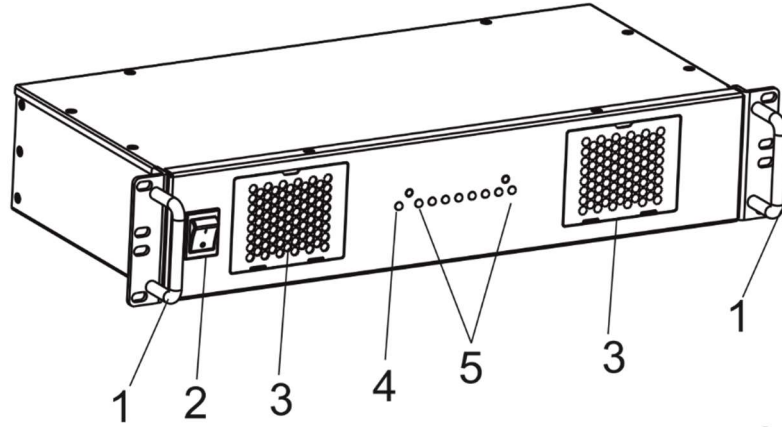

1. Handles
2. Power switch
3. Air filter holder
4. Power on indicator
5. 8 x LED output indicator

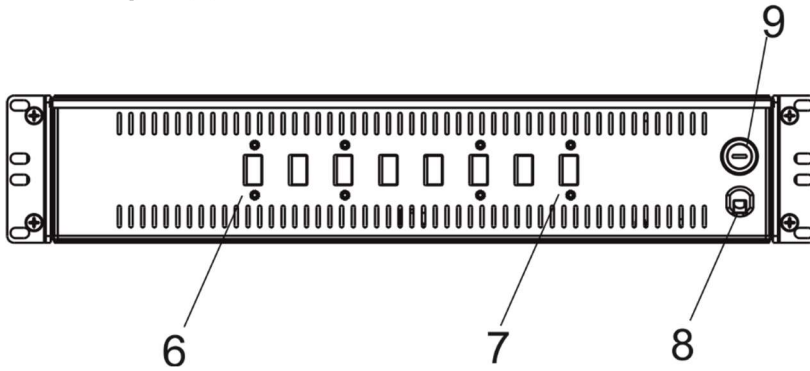

Rear panel

6. LED output 1
7. LED output 8
8. Power cord
9. Fuse holder

3. Installation

The device must be installed by a qualified electrician in accordance with all national and local electrical and construction codes and regulations.

Always Switch off the device before connecting or disconnecting a LED module.

The Ambiane Power Rack is designed for mounting into 19-inch equipment rack. Fasten the Ambiane Power Rack into rack by means of two screws on each side of the Ambiane Power Rack .

Ambiane Power Rack

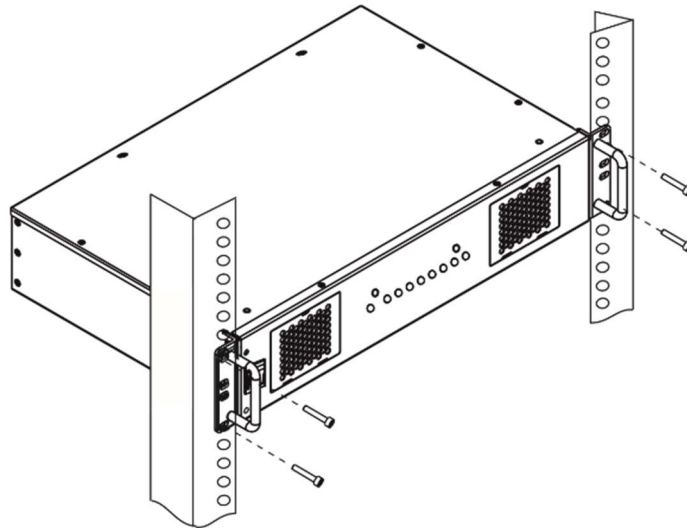

Install the counterparts (10) of connection blocks (6) on the cables (11) from LED modules and connect them to the connection blocks (6).

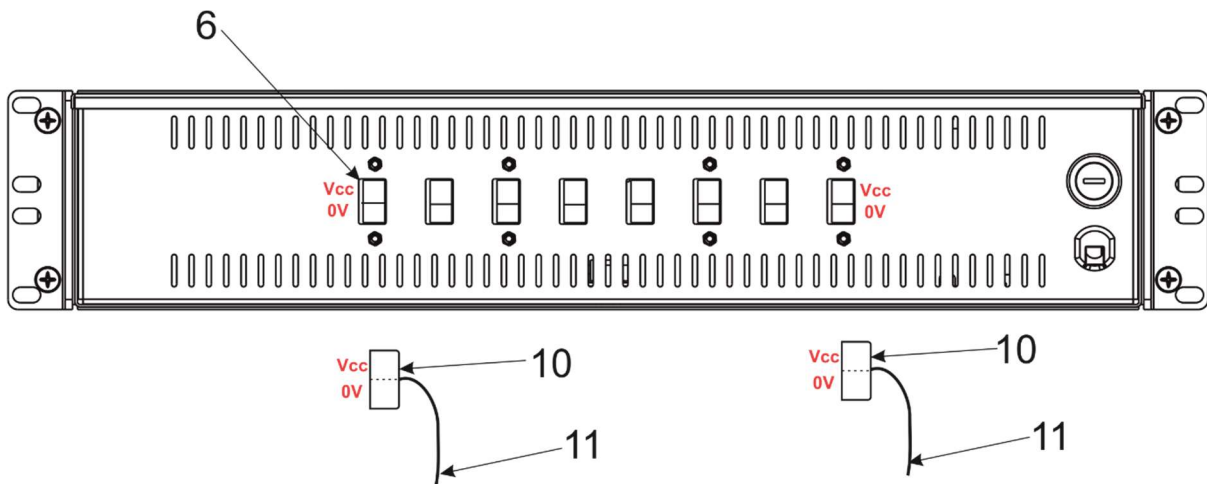

Max. cable length between one LED output of the Ambiane Power Rack and the Ambiane XP56 Recessed or Ambiane XP56 Pendant Remote is defined by the following table:

| Circular cross-section of wire | Max. cable length |
|--------------------------------|-------------------|
| 0.5 mm ² | 15 m |
| 1 mm ² | 30 m |
| 1.5 mm ² | 45 m |
| 2 mm ² | 60 m |
| 2.5 mm ² | 75 m |

Ambiane Power Rack

LED signalling

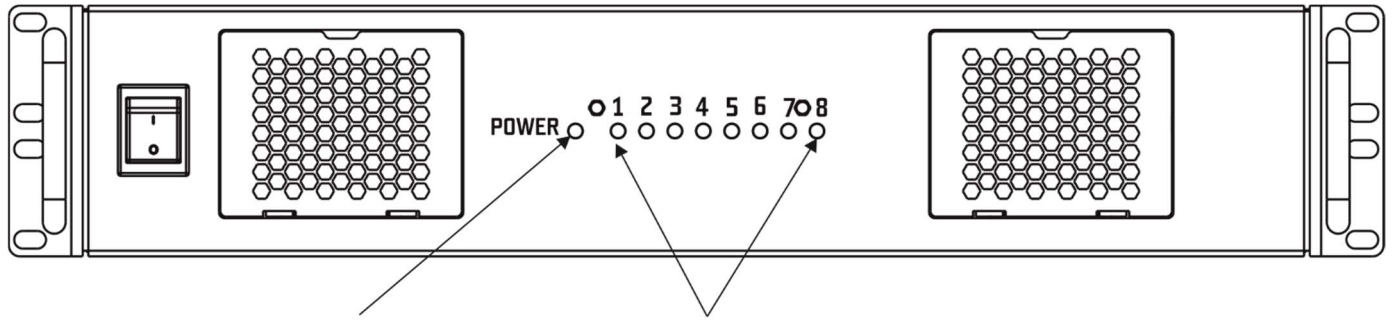

LED lights – power is on

8 LEDs for 8 outputs. If LED lights – output is under voltage. LED does not signal if LED module is (or is not) connected to the corresponding output.

4. Technical specifications

ELECTRICAL

| | |
|-------------------------|---|
| Input Voltage: | 100 – 240V AC 50/60 Hz (Ambiane Power Rack) 100 – 277V AC 50/60 Hz (Ambiane Power Rack US) |
| Max. Power Consumption: | 1350W |
| Main fuse: | T16A |
| Outputs: | 8 |
| Output Voltage: | < 50V DC |
| Max. Load per output: | 200W |
| Max. Total Load: | 1200W |

PHYSICAL

| | |
|--------------------------------|---|
| Weight: | 5.4 kg (11.9lbs) |
| Housing: | Rack Standard - 2U or Wall Mounted Brackets |
| Connections: | 8 x Terminal Block (DC power Out) 1 x Mains Power Cord with plug (CE/US) |
| Mounting Method: | Designed to Rack Box Installation |
| Protection Factor: | IP20 (Ambiane Power Rack) Dry locations only (Ambiane Power Rack US) |
| Cooling System: | Fan Cooled |
| Operating Ambient Temperature: | -20 °C / +40 °C (-4 °F / +104 °F) |

DIMENSIONS

mm [inch]

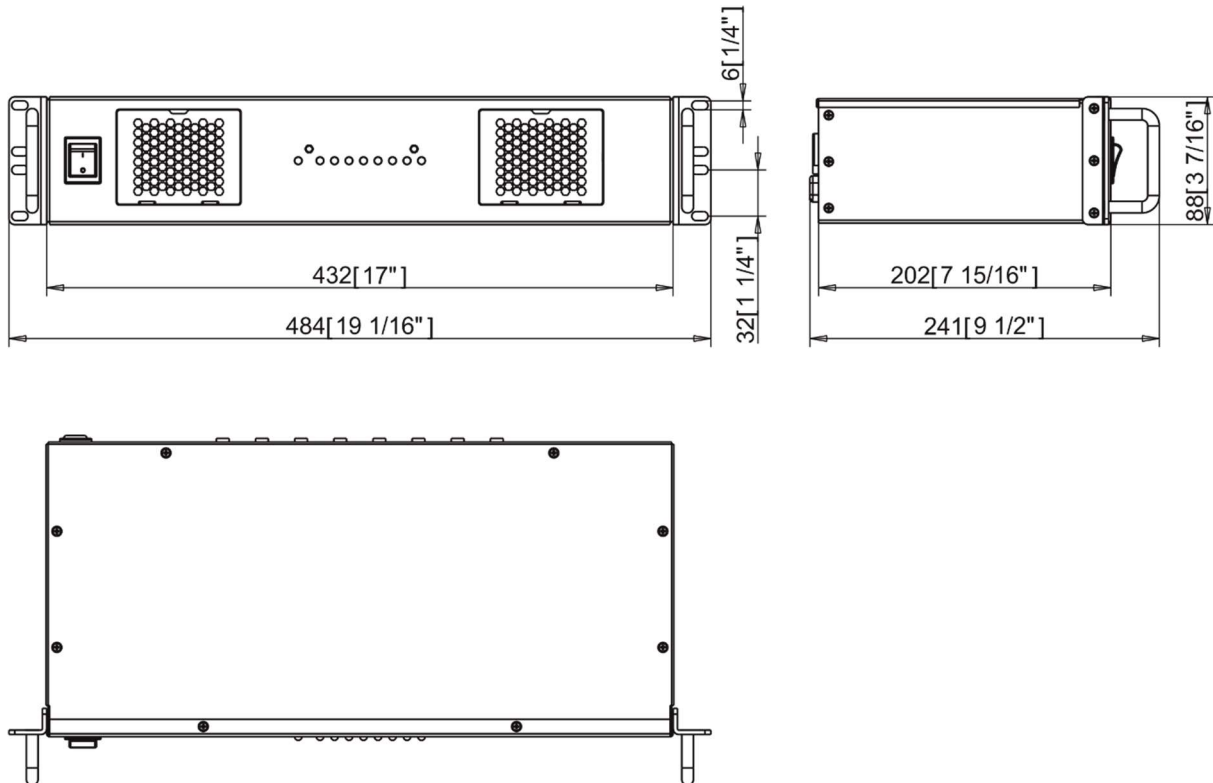

INCLUDED ITEMS

- 1 x Ambiane Power Rack or Ambiane Power Rack US
- 8 x Connector BCP-500-3GY (P/N 13053210)
- 1 x User manual

5. Cleaning and maintenance

Disconnect from the mains before starting any maintenance or cleaning work

Keep the fixture clean, maintenance and service operations are only to be carried out by a qualified person. Should you need any spare parts, please use ROBE OEM parts.

5.1 Replacing the main fuse

1. Before replacing the fuse, unplug mains lead.
2. Remove the fuse holder from the rear panel of the device with a fitting screwdriver from the housing (anti-clockwise).
3. Remove the old fuse from the fuse holder.
4. Install the new fuse into the fuse holder (only the same type and rating).
5. Replace the fuseholder in the rear panel and fix it.

5.2 Replacing air filters

The Ambiane Power Rack is equipped with 2 air filters placed in front panel of the fixture.

To replace air filters.

1. Switch off the Ambiane Power Rack.
2. Open the protective grid (1).
3. Pull out the air filter (2).
4. Clean or replace the air filter (clean the air filters with a vacuum cleaner or you can wash them and put back dry).
5. Put the filter cover back to the protective grid and close the protective grid (1).
6. Repeat the same procedure for second air filter.

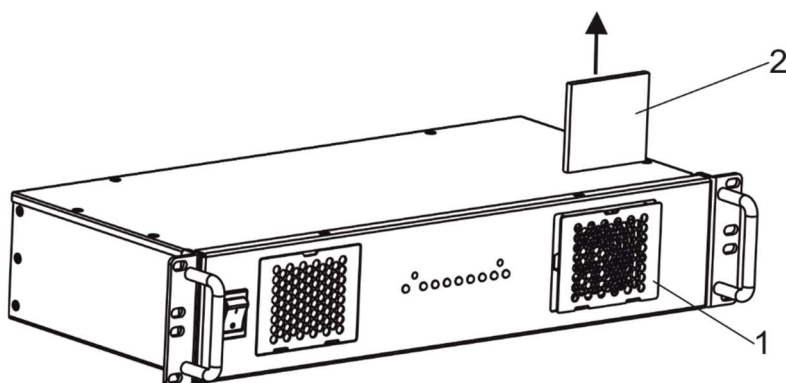

5.3 Disposing of the product

To preserve the environment please dispose or recycle this product at the end of its life according to the local regulations and codes.

Specifications are subject to change without notice

May 20, 2022

Made in CZECH REPUBLIC by ROBE LIGHTING s.r.o. Palackeho 416/20 CZ 75701 Valasske Mezirici