

# UVinere 2 UVinere 4

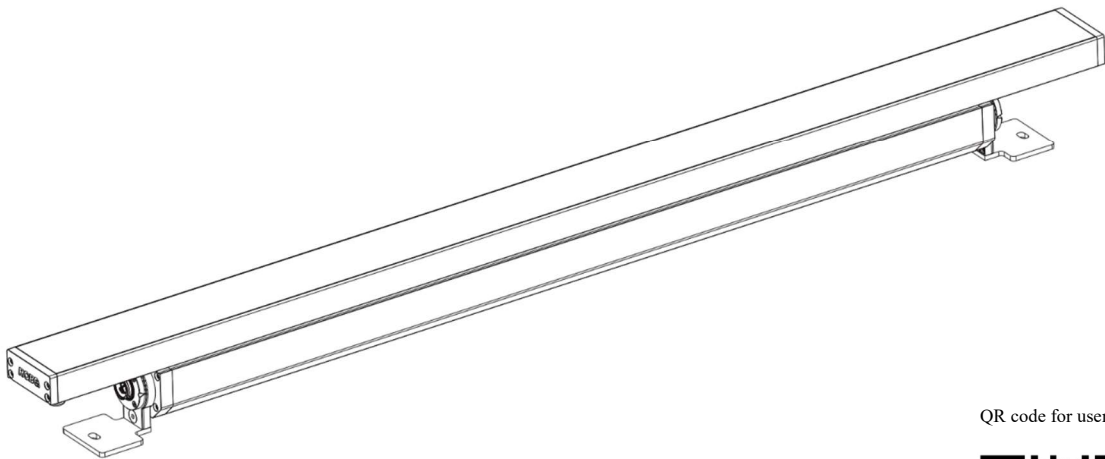

QR code for user manual



## Table of contents

1. Safety instructions .....	3
2. Fixture exterior view .....	5
3. Installation .....	5
3.1 Mounting the fixture .....	5
3.2 Connection to mains .....	6
3.3 The Booster box .....	9
3.4 The Booster box installation .....	10
3.5 Jumper cable assembling .....	12
4. Software update .....	15
5. Technical specifications .....	16
6. Cleaning and maintenance .....	20
6.1 Disposing of the product .....	20
7. ChangeLog .....	21

**FOR YOUR OWN SAFETY, PLEASE READ THIS USER MANUAL CAREFULLY  
BEFORE POWERING OR INSTALLING YOUR UVinere !  
Save it for future reference.**

This device has left our premises in absolutely perfect condition. In order to maintain this condition and to ensure safe operation, it is absolutely necessary for the user to follow the safety instructions and warnings written in this manual.

The manufacturer will not accept liability for any resulting damages caused by the non-observance of this manual or any unauthorized modification to the device.

Unauthorized modification will void warranty.

## 1. Safety instructions

**THIS LUMINAIRE IS DESIGNED WITH UV LEDS AND MUST BE INSTALLED IN COMPLIANCE WITH COMPETENT TECHNICAL DIRECTIONS TO PREVENT THE USER'S EYE AND BARE SKIN FROM EXPOSURE TO HARMFUL UV RADIATION.**  
**CE LUMINAIRE EST CONÇU POUR ÊTRE UTILISÉ AVEC DES LED UV ET DOIT ÊTRE INSTALLÉ EN STRICTE CONFORMITÉ AVEC LES INSTRUCTIONS AFIN D'ÉVITER QUE LES YEUX OU LA PEAU L'UTILISATEUR NE SOIENT EXPOSÉS AUX EFFETS NÉFASTES DES RAYONS UV.**



**CAUTION: Radiation exposure may cause blindness and cancer of skin!**

Distance from UV source	Maximum exposure time (minutes)			
	Non optical version		24°	
	UVinere 2	UVinere 4	UVinere 2	UVinere 4
1.5m (4.9ft)	37.0	18.5	-	-
2m (6.6ft)	65.7	32.9	-	-
3m (9.8ft)	147.9	74.0	27.5	-
4m (13ft)	263.0	131.5	48.9	24.5
5m (16.4ft)	410.9	205.5	76.5	38.2
6m (19.7ft)	591.7	295.9	110.1	55.0
7m (23ft)	805.4	402.7	149.8	74.9
8m (26ft)	1051.9	526.0	195.7	97.9
9m (29.5ft)	1331.4	665.7	247.7	123.9
10m (32.8ft)	1643.7	821.8	305.8	152.9

***DANGEROUS VOLTAGE CONSTITUTING A RISK OF ELECTRIC SHOCK IS PRESENT WITHIN THIS UNIT!***

This fixture should be operated only from the type of power source indicated on the marking label. If you are not sure of the type of power supplied, consult your authorized distributor or local power company.

Always disconnect the fixture from AC power before cleaning, servicing or installing.

Do not install the unit near an open flame.

During operation the housing becomes hot.

Refer servicing to qualified service personnel.

**This fixture falls under protection class I. Therefore this fixture has to be connected to a mains socket outlet with a protective earthing connection.**

The fixture was designed for outdoor use. This fixture must not be used for underwater installation.

When choosing the installation spot, please make sure that the fixture is not exposed to extreme heat or dust. Avoid using the unit in locations subject to possible impacts.

The fixture body never must be covered with cloth or other materials when the fixture is under operation.

Only operate the fixture after having checked that the housing is firmly closed and all screws are tightly fastened.

The fixture becomes hot during operation. Allow the fixture to cool approximately 30 minutes prior to servicing or maintenance.

Operate the fixture only after having familiarized yourself with its functions. Do not permit operation by persons not qualified to operate the fixture. Most damages are the result of unprofessional operation!

Immunity of the equipment is designed for electromagnetic environments E1, E2, E3 according to the standard EN55103-2 ed.2 Electromagnetic compatibility. Product family standard for audio, video, audiovisual and entertainment lighting control apparatus for professional use. Part 2: Immunity. The product (covers and cables) must not be exposed to a high frequency electromagnetic field higher than 3V/m. The installation company should check levels of possible interferences above the tested levels E1,E2,E3 given by this standard (e.g. transmitters in surrounding area) before installing the equipment. Emission of the equipment complies with the standard EN55032 Electromagnetic compatibility of multimedia equipment – Emission Requirements according to class B.

Please consider that unauthorized modifications on the fixture are forbidden due to safety reasons!

Please use the original packaging if the fixture is to be transported.

If this device will be operated in any way different to the one described in this manual, the product may suffer damages and the warranty becomes void. Furthermore, any other operation may lead to dangers like short-circuit, burns, electric shock etc.

***Warning for fixtures with Harsh Environment Finish (HEF):  
Handle with care!  
Avoid any damage to the painted surface.  
Damaging the paint may result in corrosion and loss of warranty.***

## 2. Fixture exterior view

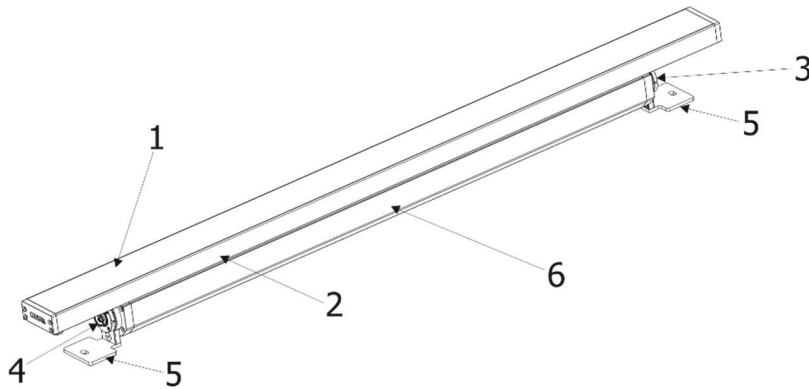

1. Transparent glass cover
2. LED module
3. Output connector
4. Input connector
5. Mounting brackets
6. Aluminium base

## 3. Installation

### 3.1 Mounting the fixture

The UVinere can be arranged in any orientation on a flat, non-flammable surface by means of two mounting brackets (5), the LED module (2) can be tilted ( $+95^\circ/-95^\circ$ ) to get access to mounting brackets (5).

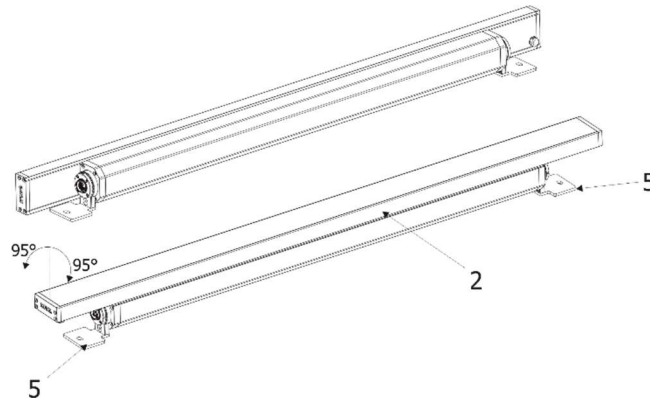

***Ensure that the structure to which you are attaching the unit is secure.***

### 3.2 Connection to mains

**The unit must be installed by a qualified electrician in accordance with all national and local electrical and construction codes and regulations.  
This device falls under class one and must be grounded!**

The UVinere is equipped with auto-switching power supply that automatically adjusts to any 50/60Hz AC power source from 120-277 Volts.

**The following wiring of the input/output connectors applies to the fixtures marked **X** on their labels only. Older versions of the UVinere have swapped D- and D+ and do not have mark **X** on their labels.**



**Input** - panel connector  
(front view)

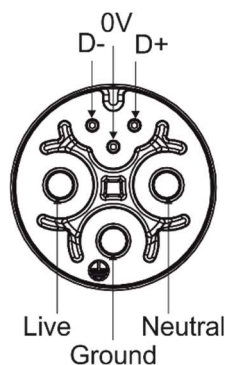

**Output** - panel connector  
(front view)

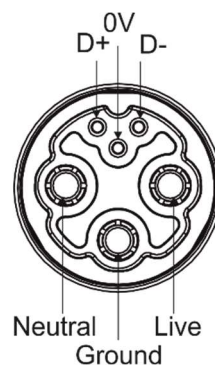

Fixture's Amphenol connectors are dust and water protected according to IP 67 by mating with related Amphenol connectors.

They cannot stay disconnected outdoor.

**The output panel connector at last fixture in the UVinere chain has to always be covered with the water-tight cap to keep declared IP rating.**

The UVinere modules should be connected to the E-box which allows power supply of the UVinere modules and their control.

**Do not connect (disconnect) Emineres UV to the E-box or Booster box and each other when they are under voltage!**

**When you change any setting of the E-box, disconnect the E-box from power and connect it to power again to activate changes which you have made.**

Examples of connection for various versions of the E-box.

Please read the E-box user manual for more information about its setting and connection to UVinere modules.

Needed cables are stated in the chapter "Technical information".

# UVinere

## E-box Daisy

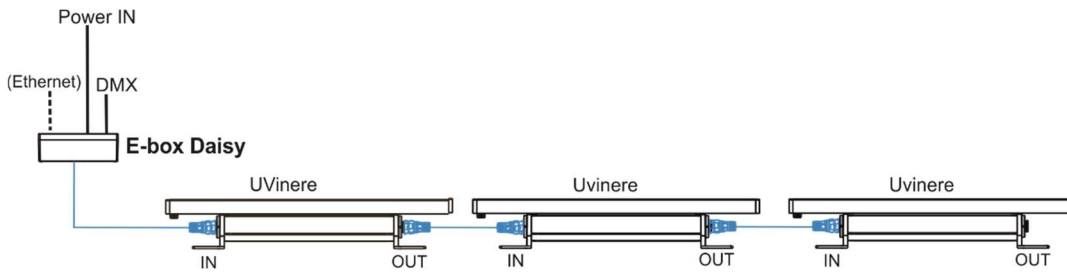

## E-box Star

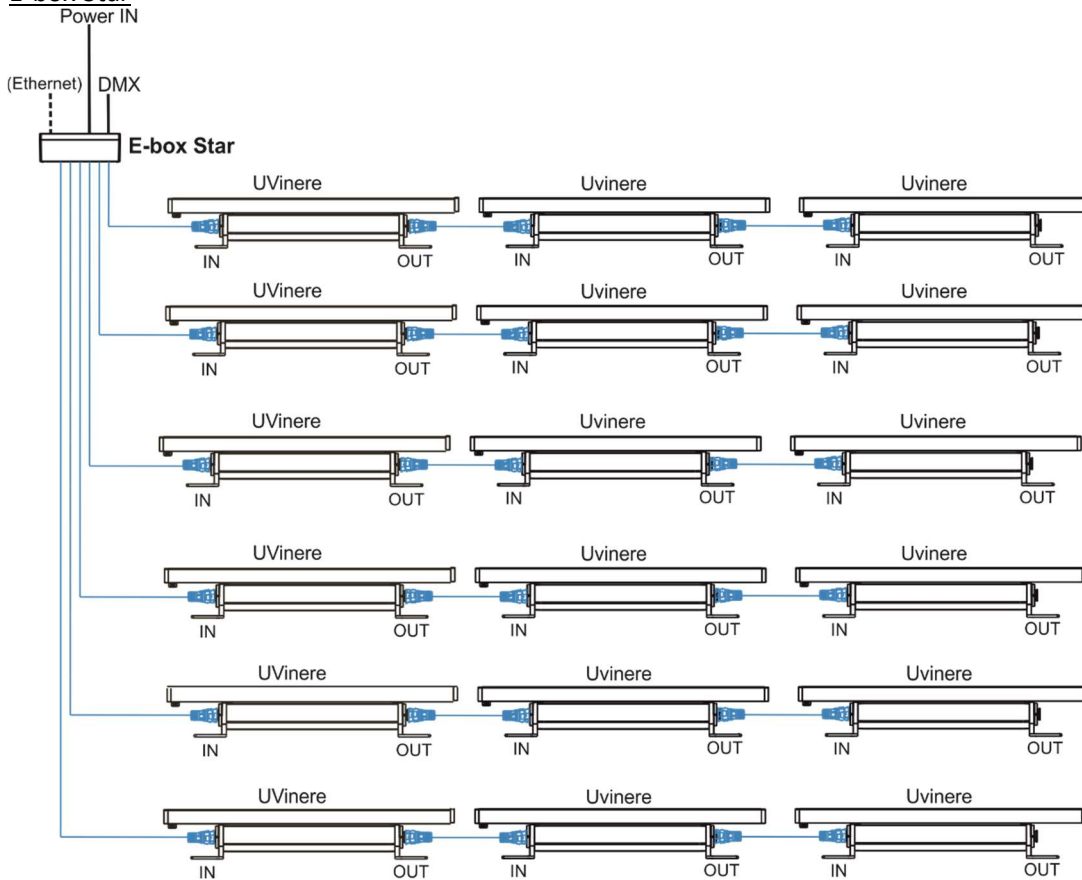

## E-box Lite

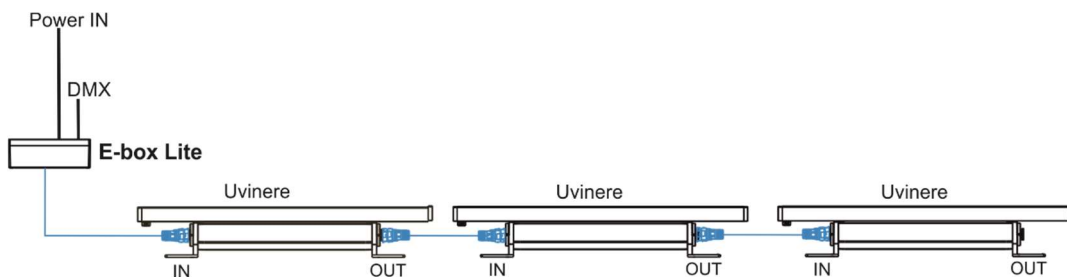

Number of connected Emineres UV to one E-box output depends on a cable length, power voltage, type of UVinere and E-box and operation mode.

## UVinere

The tables below state max. theoretical number of Emineres UV connected to the one LED output of the E-box without Booster boxes. The following tables apply for the Standard mode of E-boxes.

UVINERE 2	Voltage			
Cable length *	120V	190V	230V	277V
10 m	41	64	78	94
20 m	41	64	78	94
30 m	28	64	78	94
50 m	17	43	63	91
70 m	12	31	45	65
100 m	9	21	31	46
200 m	4	11	16	23

UVINERE 4	Voltage			
Cable length *	120V	190V	230V	277V
10 m	21	33	40	48
20 m	21	33	40	48
30 m	15	33	40	48
50 m	9	22	32	47
70 m	6	16	23	38
100 m	4	11	16	23
200 m	2	5	8	12

\* Cable length is a total cable length between E-box and last connected UVinere.

Example: Total cable length=L1+L2+L3

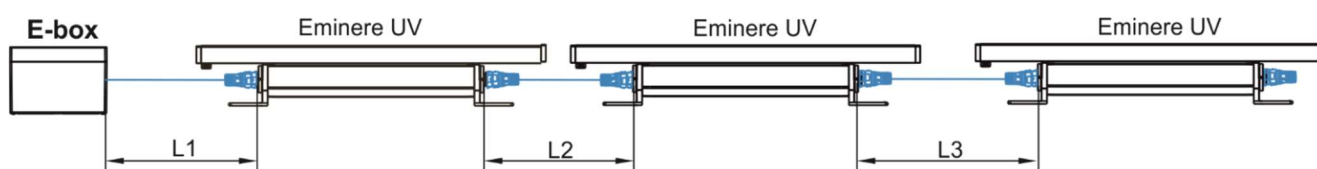

**Notice for the E-box Star:** The tables above state max. total number of Emineres UV connected to 6 LED outputs of the E-box Star (or max. number of Emineres UV connected to one output if the rest of outputs is not connected). The E-box Star has only one power input!



### 3.3 The Booster box

To compensate a voltage drop in large installation, the Booster boxes have to be connected in the chain of Emineres UV at every LED output of the E-box.

The following tables give numbers of Emineres UV after which the Booster box has to be installed in the chain of Emineres UV (at one LED output of the E-box). The following tables apply for the Standard mode of E-boxes.

UVINERE 2	Max. number of Emineres UV 2= 94			
	Voltage			
Cable length	120V	190V	230V	277V
10 m	41,82	64	78	-
20 m	41,82	64	78	-
30 m	28,56,84	64	78	-
50 m	17,34,51,68,85	43,86	63	91
70 m	12,24,36,48,60,72,84	31,62,93	45,90	65
100 m	9,18,27,36,45,54,60,72,81,90	21,42,63,84	31,62,93	46,92
200 m	4,8,12,16,20,24,28,32,36,40,44,48,52,56,60,64,68,72,76,80,84,88,92	11,22,33,44,55,66,77,88	16,32,48,64,80	23,46,69,92

UVINERE 4	Max. number of Emineres UV 4= 48			
	Voltage			
Cable length	120V	190V	230V	277V
10 m	21,42	33	40	-
20 m	21,42	33	40	-
30 m	15,30,45	33	40	-
50 m	9,18,27,36,45	22,44	32	47
70 m	6,12,18,24,30,36,42	16,32	23,46	38
100 m	4,8,12,16,20,24,28,32,36,40,44	11,22,33,44	16,32	23,46
200 m	2,4,6,8,10,12,14,16,18,20,22,24,26,28,30,32,34,36,38,40,42,44,46	5,10,15,20,25,30,35,40,45	8,16,24,32,40	12,24,36

Example: E-box Daisy, Power supply= 230V, Cable length=70m, fixture=UVinere 2

The Booster box has to be connected after every 45th UVinere 2 (fixture 45 and fixture 90) from 94 fixtures.

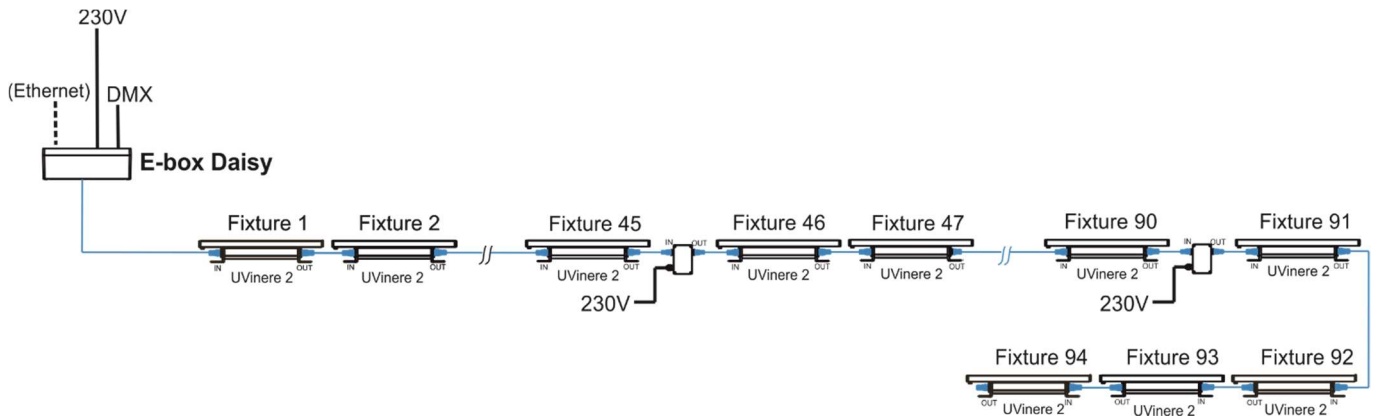

### 3.4 The Booster box installation

**ALWAYS DISCONNECT THE UVINERES FROM MAINS BEFORE CONNECTING/DISCONNECTING THE BOOSTER BOX.**

**The Booster box falls under protection class I. Therefore, every Booster box has to be connected to a mains socket outlet with a protective earthing connection.**

1. Unscrew the four screws (1) from the cover (2) on the Booster box to get access to the terminal block (3) and two mounting holes of diameter of 4.6 mm (4).
2. Screw the Booster box on a non-flammable flat surface and connect cables.

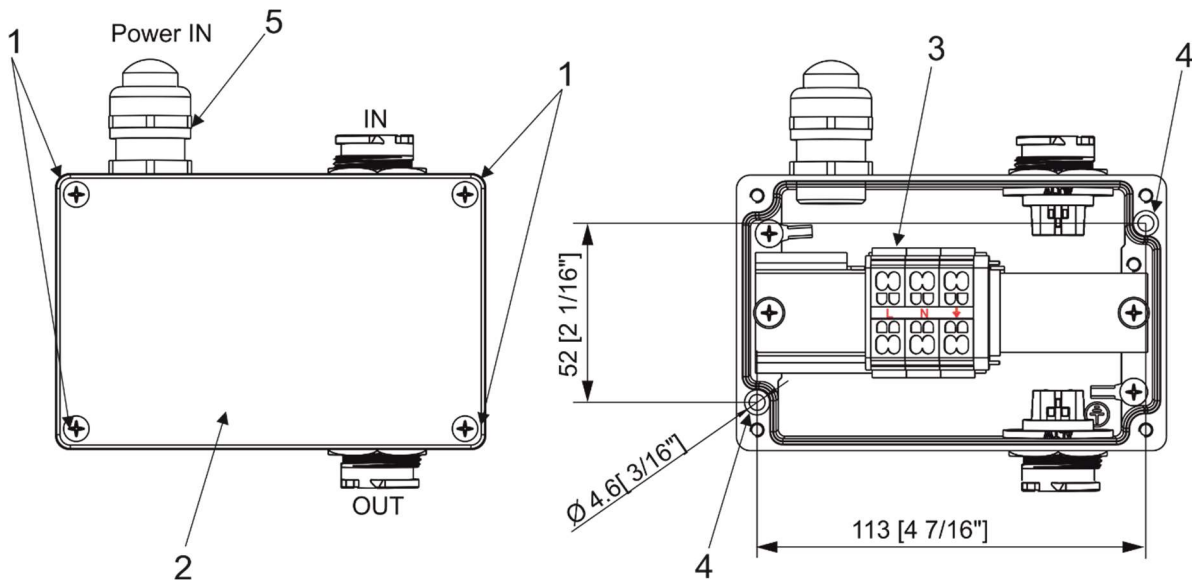

The Cable gland M20x1.5 for Power IN (5) is intended for a cable of a diameter of 7-13mm. Remove the end cap from the cable gland before passing the cable.

Power connection

	L	N	⊕ (earth)
Core (EU)	Braun	Blue	Green/yellow
Core (US)	Black	White	Green

We recommend to apply an adequate layer of the paste LOCTITE 5331 on the plastic holder of the cable gland before inserting it into the body of the gland and an adequate layer of the paste LOCTITE 577 on the thread of the gland body.

Cable gland M20 MS:

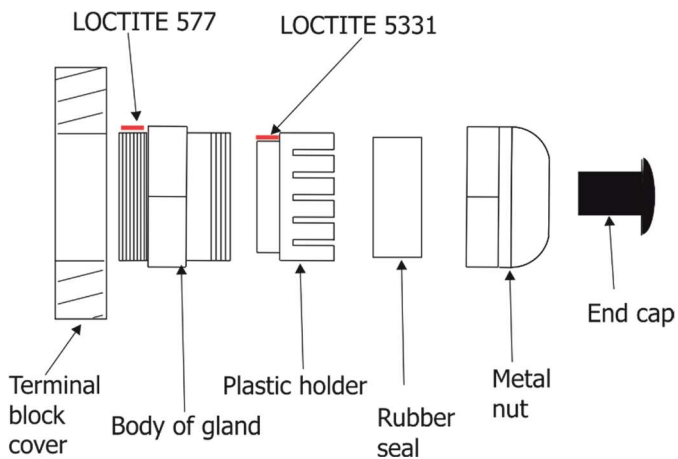

The cable gland M20 MS with a standard seal serves for a cable of diameter of 6-12mm, for smaller diameter of cable (4-8mm) you have to remove the original seal from the cable gland M20 and use the enclosed reducing seal instead of it. The reducing seal for diameter of cable 4-8mm (P/N 13051388) is enclosed in the Booster box.

**1 x standard seal** - part of cable gland M20 MS  
(for diameter of cable: 6-12mm)

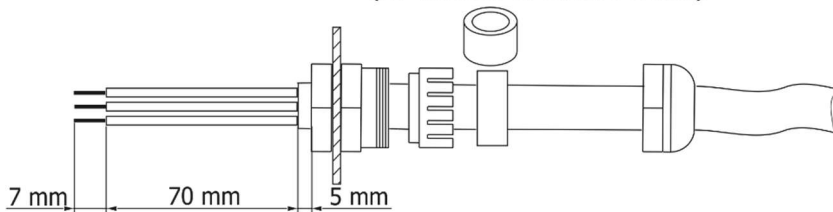

**1 x reducing seal** (P/N 13051388) - enclosed, standard seal has to be removed before installing this seal.  
(for diameter of cable: 4-8mm)

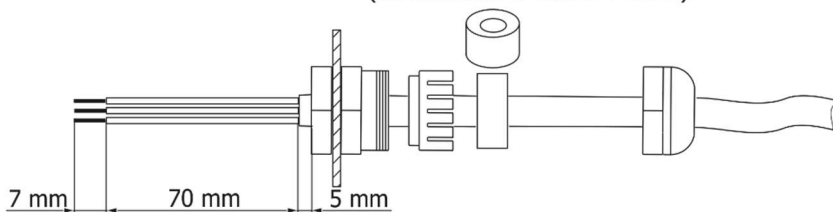

3. Screw the cover (2) back on the Booster box.

### 3.5 Jumper cable assembling

1. Dismantle the connector and slide its parts onto the cable (6).  
Use the seal with inner diameter of 14.5 mm for the Anolis cable (P/N 13053138 or P/N 13053139).  
The seal with inner diameter of 14.5 mm serves for cable of diameter 10-14.5mm.  
The seal with inner diameter of 10 mm serves for cable of diameter 8-10mm.

Parts of the connector

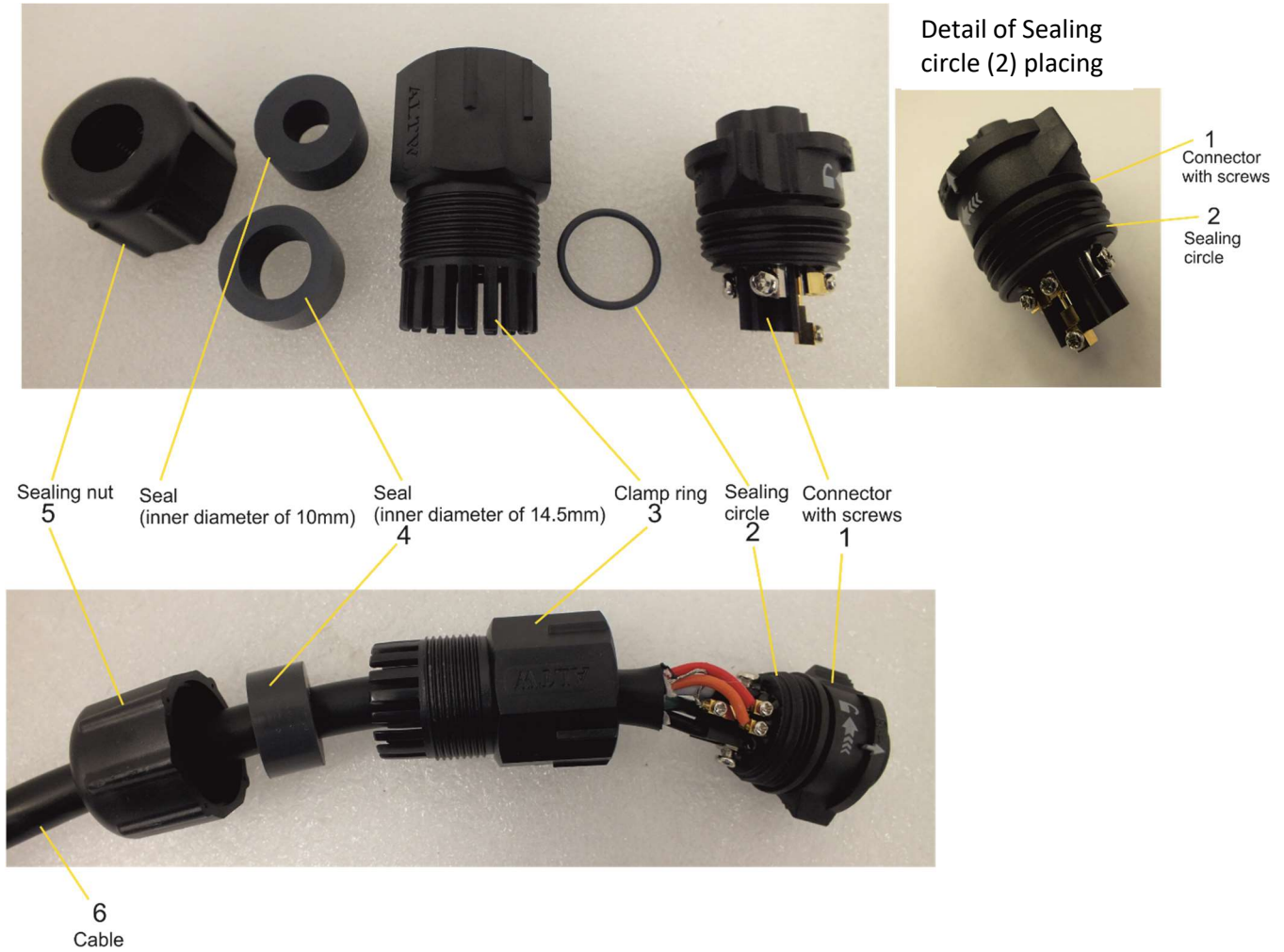

2. Put the sealing circle (2) on the connector with screws (1).
3. Remove insulation from the cable (6) and from individual wires and fasten three terminals on data wires.

CE version

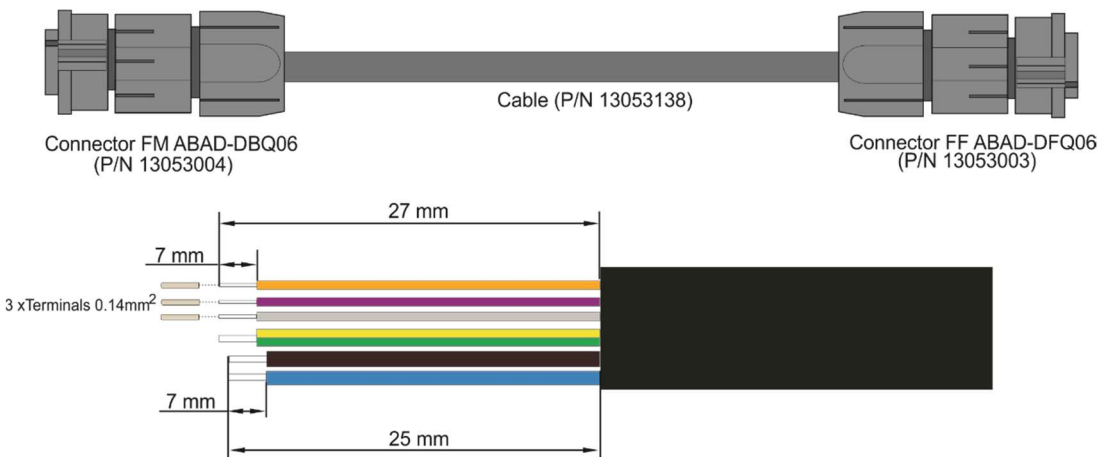

# UVinere

## US version

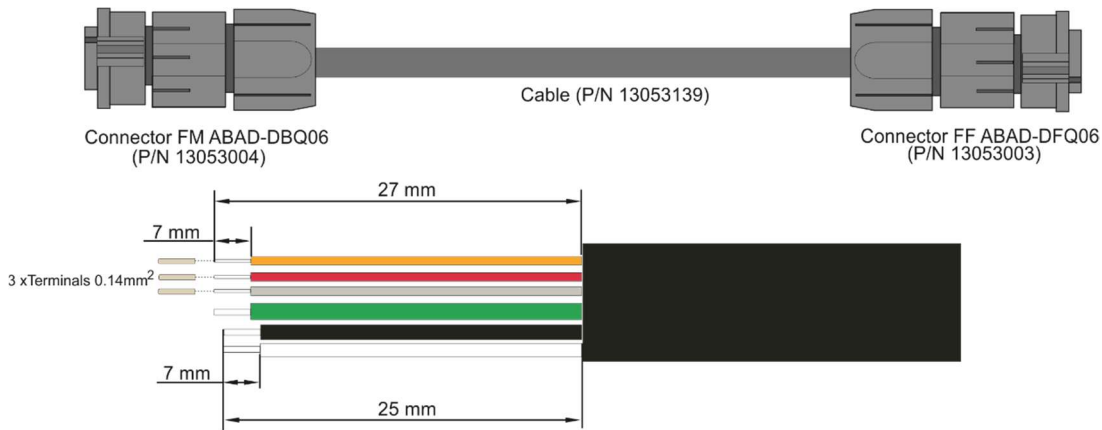

4. Put parts of the connector on the cable (6) and connect wires to the connector. First connect power wires (L,N, Earth) and after that data wires (D+, D-, 0V). Avoid excessive torsion of data wires!

## CE version

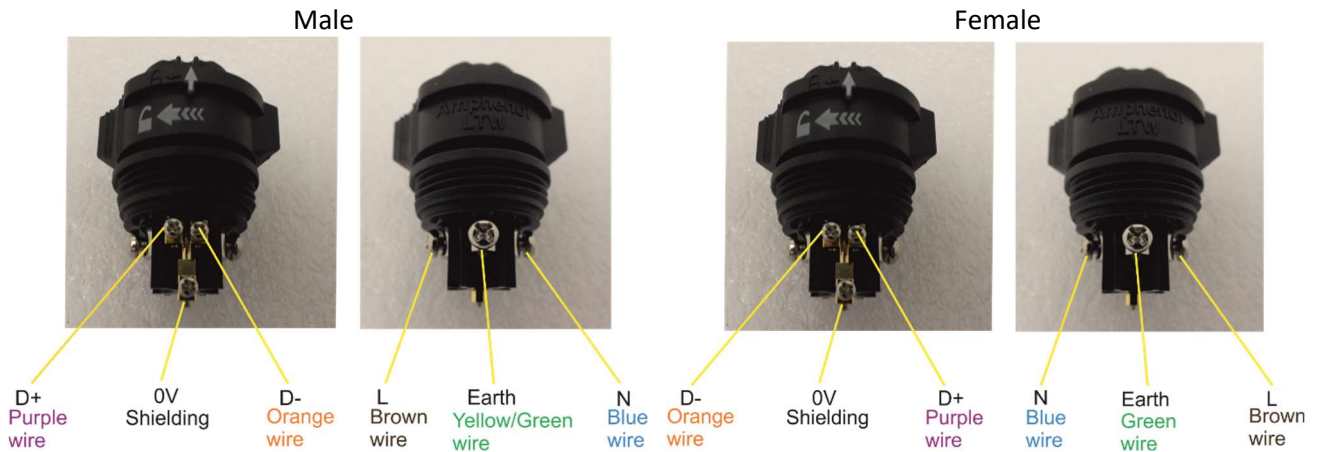

## US version

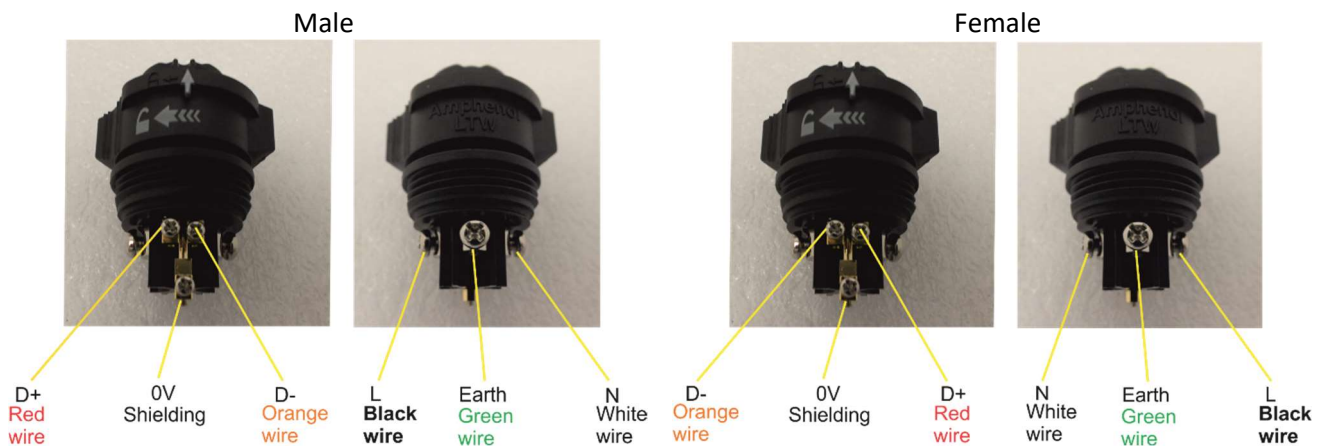

5. After connecting wires to the connector, tighten the three data wires (D+,D-, 0V) by means of the cable binder (7).



7  
Cable binder

6. Screw the clamp ring (3) to the connector (1), insert the seal (4) to the clamp ring (3) and tighten the sealing nut (5) enough. During the steps DO NOT TWIST the cable (6).

7. Use the same procedure to assemble the connector on the second end of the cable.

**IMPORTANT**

Do not bend the cable near to the connector, minimum distance for bending is 50mm.

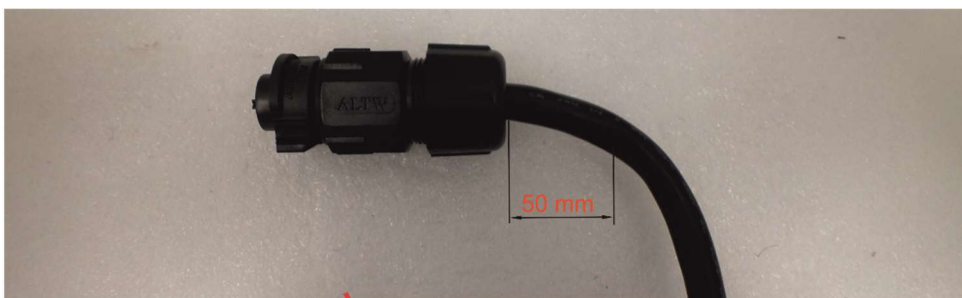

## 4. Software update

Software update of UVinere has to be done by means of the software ROBE Uploader running on PC. The ROBE Uploader is a software for automatized software update of ROBE fixtures. The ROBE Uploader switches Emineres UV to the update mode automatically.

Please see <https://www.robe.cz/robe-uploader/> for more information.

### **DMX or Ethernet connection via E-box**

If the option **Standard** is selected from the menu **E-box mode** and LED modules are connected in series, the E-box will be updated including connected UVinere modules. You have to use the file EminereEbox.lib in the ROBE Uploader for this operating mode.

If the option **Pass-Thr** is selected from the menu **E-box mode** and LED modules are connected in series, you have to do the following steps to update Emineres UV including the E-box:

1. Set the E-box to the Standard mode and switch it off/on. Only E-box will be shown in the ROBE Uploader. You have to use the file EminereEbox.lib in the ROBE Uploader for software update of the E-box and connected LED modules.
2. After updating, set the E-box to the Pass-Thorough mode and switch it off/on.

For more information about updating please see the E-box Lite/Daisy/Star user manual.

## 5. Technical specifications

### Power supply

- Electronic auto-ranging
- Input voltage: 120 - 277V AC, 50/60 Hz
- Power consumption:
  - UVinere 2: 45W
  - UVinere 4: 85W
- Inrush current:
  - UVinere 2: <70A/250µs
  - UVinere 4: <100A/200µs

### Optic

- Light source:
  - UVinere 2: 16 x UV LEDs
  - UVinere 4: 32 x UV LEDs
- UV LEDs Wave Length: 365nm
- Beam Angle:
  - optical version: 24°
  - non-optical version: 92°
- Projected LEDs Life: 10.000 Hrs

### Compatible drivers

- E-box Daisy
  - 1 Output
  - 1 Main power Input
  - Control: DMX, Art-Net, sACN , W-DMX control, RDM
  - Pixel control (1px= 1ft)
  - 120-277V Input
  - Connection via terminal blocks, inlets via grommet
  - IP67
- E-box Star
  - 6 outputs
  - 1 Main power Input
  - Control: DMX, Art-Net, sACN , W-DMX control, RDM
  - Pixel control (1px= 1ft)
  - 120-277V Input
  - Connection via terminal blocks, inlets via grommet
  - IP67
- E-box Lite
  - 1 output
  - 1 Main power Input
  - Control: DMX, W-DMX control, RDM
  - Pixel control (1px= 1ft)
  - 120-277V Input
  - Connection via screw terminal blocks, inlets via grommet
  - IP67

### Mounting method

- Via two L-shape brackets
- LED module "tilt" adjustment range: -95°/+95°



**Sizes**

- UVinere 2 (600mm / 2ft)
- UVinere 4 (1200mm / 4ft)

**Housing**

- Aluminium extruded body with die-casted end caps
- Tempered glass

**Cooling system**

- Convection

**Total heat dissipation**

- UVinere 2: 113 BTU/h (calculated)
- UVinere 4: 214 BTU/h (calculated)

**Protection factor**

- CE: IP 67
- US: Suitable for wet location

**Impact rating**

- CE: IK06

**Operating ambient temperature range**

- -20°C /+40°C (-4°F /+104°F)

**Operating temperature**

- +67°C @ Ambient +40°C (+153°F @ Ambient +104°F)

**Connection**

- Input: panel connector Amphenol ABAB-DMQ06000021-IN (P/N13052952)
- Output: panel connector Amphenol ABAB-DAQ06000021 (P/N13052953) + water-tight cap

**Weight**

- UVinere 2: 4.05 kg (8.92 lbs)
- UVinere 4: 7.68 kg (16.93 lbs)

# UVinere

## Dimensions (All dimensions in mm [inch])

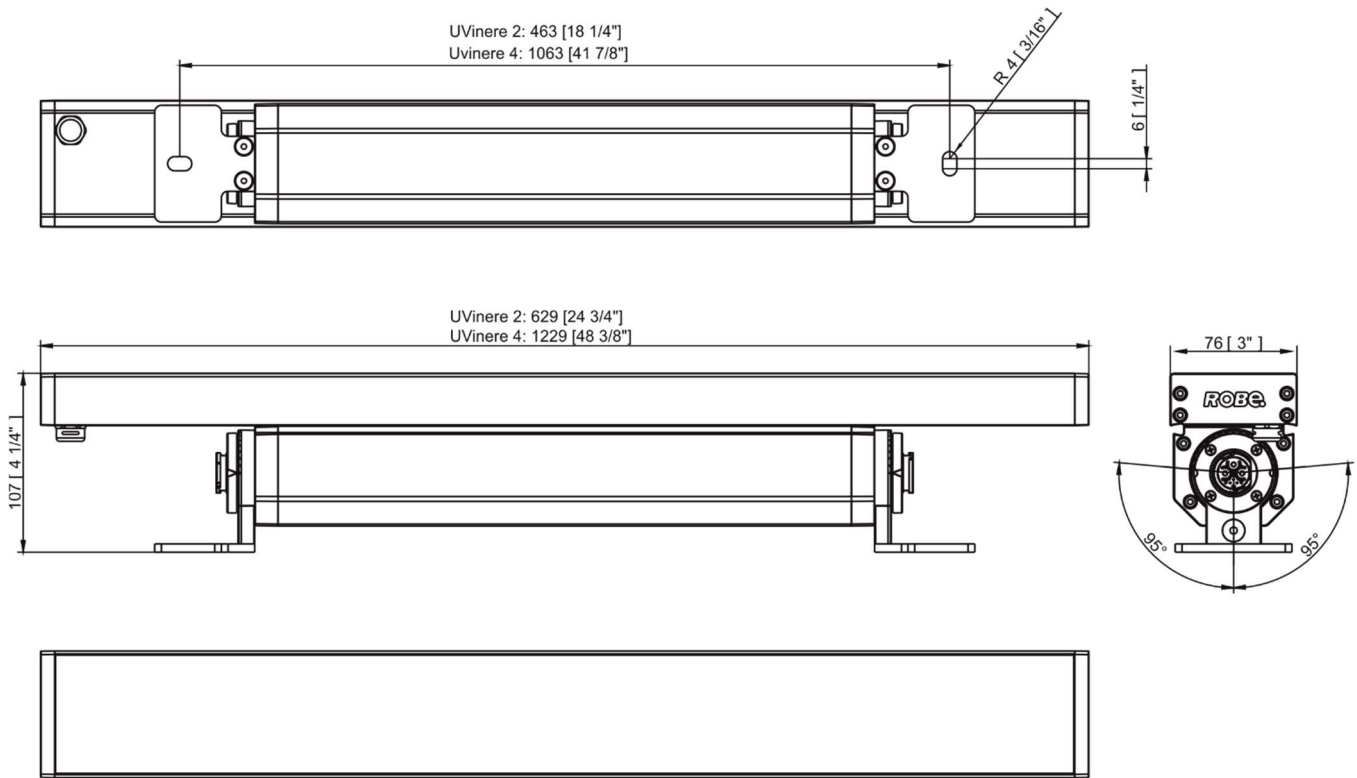

• Booster box

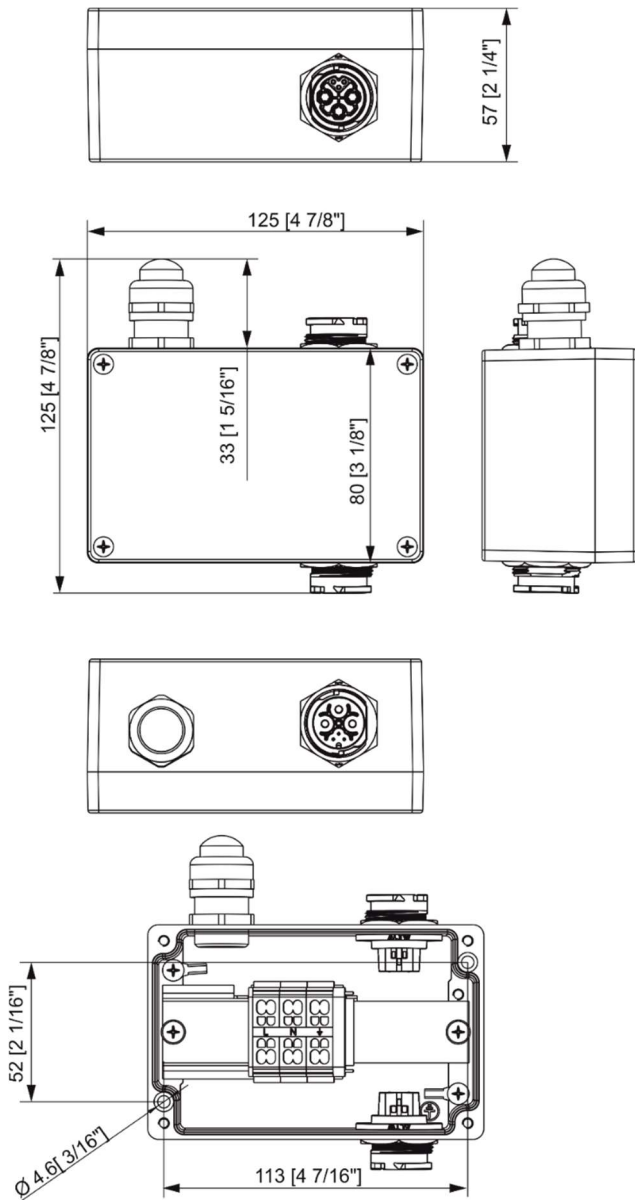

**Included items**

- 1 x UVinere
- 1 x User manual

**Optional accessories**

CE Leader Cables FF:

- Leader Cable FF 2m (P/N 13053005)
- Leader Cable FF 5m (P/N 13053006)
- Leader Cable FF 10m (P/N 13053007)
- Leader Cable FF 25m (P/N 13053008)
- Leader Cable FF 50m (P/N 13053009)

US Leader Cables FF:

- Leader Cable FF 2m (P/N 13053010)
- Leader Cable FF 5m (P/N 13053011)
- Leader Cable FF 10m (P/N 13053012)
- Leader Cable FF 25m (P/N 13053013)
- Leader Cable FF 50m (P/N 13053014)

Jumper Cables FF/FM:

Jumper Cable FF/FM 0,25m (P/N 13053052)  
Jumper Cable FF/FM 0,5m (P/N 13053053)  
Jumper Cable FF/FM 1m (P/N 13053054)  
Jumper Cable FF/FM 2m (P/N 13053055)  
Jumper Cable FF/FM 3m (P/N 13053056)  
Jumper Cable FF/FM 5m (P/N 13053057)  
Jumper Cable FF/FM 10m (P/N 13053058)

Waterproof Cover Cap FM ZAHB-0006 (P/N 17031173)

Field Installable Connector FF (P/N 13053003)  
Field Installable Connector FM (P/N 13053004)

E-boxes:

E-box Daisy (P/N 10063655)  
E-box Daisy/W (P/N 10063638)  
E-box Lite (P/N 10063657)  
E-box Lite/W (P/N 10063653)  
E-box Star (P/N 10063656)  
E-box Star/W (P/N 10063644)

Booster box (P/N 10063712)

Cable Cover for Eminere 2 RAL9011 (P/N 10980485)  
Cable Cover for Eminere 4 RAL9011 (P/N 10980487)

Shield for Eminere 2 RAL9011 (P/N 10980489)  
Shield for Eminere 4 RAL9011 (P/N 10980491)

Black Glass Adaptor for UVinere 2 RAL9011 (P/N 10980773)  
Black Glass Adaptor for UVinere 4 RAL9011 (P/N 10980648)

## 6. Cleaning and maintenance

***DANGER !***  
***Disconnect from the mains before starting any maintenance or cleaning work***

Rinse off loose dirt with low pressure water spray. Wash the housing with a soft brush or sponge and a mild, non-abrasive washing detergent. Rinse it.

Maintenance and service operations are only to be carried out by a qualified person.

Should you need any spare parts, please use ROBE OEM parts.

### 6.1 Disposing of the product

To preserve the environment please dispose or recycle this product at the end of its life according to the local regulations and codes.

## 7. ChangeLog

This section summarizes changes in the user manual.

Version of manual	Date of issue	Description of changes
1.0	18/05/2022	QR code added
1.1	01/12/2022	Beam angles more specified
1.2	09/01/2023	Eminere UV update added
1.3	18/01/2023	Device renamed to UVinere
1.4	10/02/2023	DMX chart ver. 3.2

*Specifications are subject to change without notice.*

*February 10, 2023*

*Copyright © 2019-2023 Robe Lighting - All rights reserved*

Made in CZECH REPUBLIC by ROBE LIGHTING s.r.o. Palackeho 416/20 CZ 75701 Valasske Mezirici

**DMX protocol for: Eminere 1/2/3/4; Eminere Side 1/2/3/4;  
Eminere Inground 2/4; Eminere Remote 1/2/3/4;  
UVinere 2/4; UVinere Remote 1/2/4**

Version: 3.2 (23 modes in total), software version 3.0 and higher

Mode/Channels in all								Mode 1: RGBW(A)-8bit, Mode 2: RGB 8-bit, Mode 3: full RGBW(A)	
1	2	3	4	5	6	7	8-10	Mode 4: White-full control, Mode 5: Reduced RGBW(A)	
4	3	12	3	6	8	15	Reserved	Mode 6- Reduced RGBW(A)+white control	
								Mode 7- full RGBW(A)+virtual colour wheel	
								RGBW(A) / RGB modes	
Mode/channels							DMX Value	Function	Type of control
1	2	3	4	5	6	7			
-	-	-	-	-	-	1	0	<b>Special functions</b> No function	step
							1-2	Save current DMX values to fixture as initial DMX values.	step
							3-4	Show saved initial DMX values	step
							5-6	Run factory demo sequences at switching fixture on (without DMX)	step
							7-255	Reserved	
1	1	1	-	1	1	2	0-255	<b>Red</b> Red LEDs saturation control (0-100%)	proportional
-	-	2	-	-	-	3	0-255	<b>Red Fine</b> Red LEDs saturation control fine	proportional
2	2	3	-	2	2	4	0-255	<b>Green</b> Green LEDs saturation control (0-100%)	proportional
-	-	4	-	-	-	5	0-255	<b>Green Fine</b> Green LEDs saturation control fine	proportional
3	3	5	-	3	3	6	0-255	<b>Blue</b> Blue LEDs saturation control (0-100%)	proportional
-	-	6	-	-	-	7	0-255	<b>Blue Fine</b> Blue LEDs saturation control fine	proportional
4	-	7	-	4	4	8	0-255	<b>White (Amber)</b> White LEDs saturation control (0-100%)	proportional
-	-	8	-	-	-	9	0-255	<b>White (Amber) Fine</b> White LEDs saturation control fine	proportional
-	-	9	1	-	5	10	0	<b>Green correction</b> Uncorrected white	step
							1-127	Minus green --> uncorrected white	proportional
							128	Uncorrected white (128=default)	step
							129-255	Uncorrected white --> Plus green	proportional
-	-	10	2	-	6	11	0	<b>Colour temperature correction (CTC)</b> No function	step
							1-10	Tungsten dimming 2700 K	step
							11-20	Tungsten dimming 3200 K	step
							21-255	Colour temperature changing from 1800 K --> 6500 K (21-1800K, 66-2700K, 91-3200K,141-4200K, 211-5600K, 255-6500K)	proportional
-	-	-	-	-	-	12	0	<b>Virtual Colour Wheel</b> No function	step

DMX protocol

Mode/channels							DMX Value	Function	Type of control
1	2	3	4	5	6	7			
							1-2	White 1800 K	step
							3-4	White 2700 K	step
							5-6	White 3200 K	step
							7-8	White 4200 K	step
							9-10	White 5600 K	step
							11-12	White 6500 K	step
							13	Blue (Blue=full, Red+Green+White/Amber=0)	step
							14-23	Red=0, Green->up,Blue =full, White/Amber=0	proportional
							24	Cyan (Red=0, Green=full, Blue =full, White/Amber=0)	step
							25-34	Red=0, Green=full, Blue->down, White/Amber=0	proportional
							35	Green (Red=0, Green=full, Blue =0, White/Amber=0)	step
							36-45	Red->up, Green=full, Blue=0, White/Amber=0	proportional
							46	Yellow (Red=full, Green=full, Blue=0, White/Amber=0)	step
							47-56	Red=full, Green->down, Blue=0, White/Amber=0	proportional
							57	Red(Red=full, Green=0, Blue=0, White/Amber=0)	step
							58-67	Red=full, Green=0, Blue->up, White/Amber=0	proportional
							68	Magenta (Red=full, Green=0, Blue=full, White/Amber=0)	step
							69-78	Red -> down, Green=0, Blue=full, White/Amber=0	proportional
							79	Blue (Red=0, Green=0, Blue=full, White/Amber=0)	step
								<b>Transition effects</b>	
							80-87	Rainbow effect (with fade time) from slow-> fast	proportional
							88-95	Rainbow effect (without fade time) from slow-> fast	proportional
							96-103	Full dynamic white (1800K->6500K->1800K) (with fade time) from slow-> fast	proportional
							104-111	Full dynamic white (1800K->6500K->1800K) (without fade time) from slow-> fast	proportional
							112-119	Dynamic warm white (1800K-3000K-1800K) (with fade time) from slow-> fast	proportional
							120-127	Dynamic warm white (1800K-3000K-1800K) (without fade time) from slow-> fast	proportional
							128-135	Rainbow effect + full dynamic white (with fade time) from slow-> fast	proportional
							136-143	Rainbow effect + full dynamic white (without fade time) from slow-> fast	proportional
							145-151	Blue/Green effect (with fade time) from slow-> fast	proportional
							152-159	Blue/Green effect (without fade time) from slow-> fast	proportional
							160-167	Red/Blue effect (with fade time) from slow-> fast	proportional
							168-175	Red/Blue effect (without fade time) from slow-> fast	proportional
							176-183	Green/Red effect (with fade time) from slow-> fast	proportional
							184-191	Green/Red effect (without fade time) from slow-> fast	proportional
							192-199	Blue/4000K effect (with fade time) from slow-> fast	proportional
							200-207	Blue/4000K effect (without fade time) from slow-> fast	proportional
							208-215	Green/4000K effect (with fade time) from slow-> fast	proportional
							216-223	Green/4000K effect (without fade time) from slow-> fast	proportional
							224-231	Red/4000K effect (with fade time) from slow-> fast	proportional
							232-239	Red/4000K effect (without fade time) from slow-> fast	proportional
							240-255	Reserved	
						<b>13</b>		<b>Shutter/Strobe</b>	
							0-31	Shutter closed	step
							32-63	Shutter open	step

DMX protocol

Mode/channels							DMX Value	Function	Type of control
1	2	3	4	5	6	7			
							64-95	Strobe-effect from slow to fast	proportional
							96-127	Shutter open	step
							128-143	Opening pulse in sequences from slow to fast	proportional
							144-159	Closing pulse in sequences from fast to slow	proportional
							160-191	Shutter open	step
							192-223	Random strobe-effect from slow to fast	proportional
							224-255	Shutter open	step
-	-	11	3	5	7	14		<b>Dimmer</b>	
							0-255	Light intensity coarse (0-100%)	proportional
-	-	12	-	6	8	15		<b>Dimmer Fine</b>	
							0-255	Light intensity fine	proportional
Copyright © 2022-2023 Robe Lighting s.r.o. - All rights reserved									
All Specifications subject to change without notice									



**DMX protocol for: Eminere 1/2/3/4; Eminere Side 1/2/3/4;  
Eminere Inground 2/4; Eminere Remote 1/2/3/4;  
UVinere 2/4; UVinere Remote 1/2/4**

Version: 3.2 (23 modes in total)

Mode/Channels in all				Mode 11: TW – White selection + Dimmer, Mode 12: TW – WW + CW	
11	12	13	14-16	Mode 13: PW - Dimmer	
3	4	2	Reserved	<i>Mode 13 is suitable for UVinere and UVinere Remote</i>	
<b>TW and PW modes</b>					
Mode/channels			DMX Value	Function	Type of control
11	12	13			
1	-	-	0 - 255	<b>White colour selection</b> White from 2700 K - 6500 K	proportional
-	1	-	0 - 255	<b>Warm White</b> Warm White LEDs saturation control (0-100%)	proportional
-	2	-	0 - 255	<b>Cool White</b> Cool White LEDs saturation control (0-100%)	proportional
2	3	1	0 - 255	<b>Dimmer</b> Light intensity coarse (0 - 100%)	proportional
3	4	2	0 - 255	<b>Dimmer Fine</b> Light intensity fine	proportional
Copyright © 2022-2023 Robe Lighting s.r.o. - All rights reserved					
All Specifications subject to change without notice					

**DMX protocol for: Eminere 1/2/3/4; Eminere Side 1/2/3/4;  
Eminere Inground 2/4; Eminere Remote 1/2/3/4;**

Version: 3.2 (23 modes in total)

Mode/Channels in all					Mode 16: RGBW(A) pixels, Mode 17 RGB pixels, Mode 18: TW pixels, Mode 19- PW dimmer pixels		
17	18	19	20	21-23			
16	12	8	8	Reserved			
Mode/channels					DMX Value	Function	Type of control
17	18	19	20				
1	1	-	-	0 - 255	<b>Red 1 -Eminere 1/2/3/4</b> Red LEDs saturation control (0-100%)	proportional	
2	2	-	-	0 - 255	<b>Green 1-Eminere 1/2/3/4</b> Green LEDs saturation control (0-100%)	proportional	
3	3	-	-	0 - 255	<b>Blue 1-Eminere 1/2/3/4</b> Blue LEDs saturation control (0-100%)	proportional	
4	-	-	-	0 - 255	<b>White (Amber) 1-Eminere 1/2/3/4</b> White LEDs saturation control (0-100%)	proportional	
5	4	-	-	0 - 255	<b>Red 2 -Eminere 2/3/4</b> Red LEDs saturation control (0-100%)	proportional	
6	5	-	-	0 - 255	<b>Green 2-Eminere 2/3/4</b> Green LEDs saturation control (0-100%)	proportional	
7	6	-	-	0 - 255	<b>Blue 2-Eminere 2/3/4</b> Red LEDs saturation control (0-100%)	proportional	
8	-	-	-	0 - 255	<b>White (Amber) 2-Eminere 2/3/4</b> White LEDs saturation control (0-100%)	proportional	
9	7	-	-	0 - 255	<b>Red 3-Eminere 3/4</b> Red LEDs saturation control (0-100%)	proportional	
10	8	-	-	0 - 255	<b>Green 3-Eminere 3/4</b> Green LEDs saturation control (0-100%)	proportional	
11	9	-	-	0 - 255	<b>Blue 3-Eminere 3/4</b> Blue LEDs saturation control (0-100%)	proportional	
12	-	-	-	0 - 255	<b>White (Amber) 3-Eminere 3/4</b> White LEDs saturation control (0-100%)	proportional	
13	10	-	-	0 - 255	<b>Red 4-Eminere 4</b> Red LEDs saturation control (0-100%)	proportional	
14	11	-	-	0 - 255	<b>Green 4-Eminere 4</b> Green LEDs saturation control (0-100%)	proportional	
15	12	-	-	0 - 255	<b>Blue 4-Eminere 4</b> Blue LEDs saturation control (0-100%)	proportional	
16	-	-	-	0 - 255	<b>White (Amber) 4 -Eminere 4</b> White LEDs saturation control (0-100%)	proportional	
-	-	1	-		<b>Warm White 1 -Eminere 1/2/3/4</b> Warm White LEDs saturation control (0-100%)	proportional	
-	-	2	-	0 - 255	<b>Cool White 1-Eminere 1/2/3/4</b> Cool White LEDs saturation control (0-100%)	proportional	
-	-	3	-		<b>Warm White 2-Eminere 2/3/4</b>		

## DMX protocol

Mode/channels				DMX Value	Function	Type of control
17	18	19	20			
				0 - 255	Warm White LEDs saturation control (0-100%)	proportional
-	-	4	-	0 - 255	<b>Cool White 2-Eminere 2/3/4</b> Cool White LEDs saturation control (0-100%)	proportional
-	-	5	-	0 - 255	<b>Warm White 3-Eminere 3/4</b> Warm White LEDs saturation control (0-100%)	proportional
-	-	6	-	0 - 255	<b>Cool White 3-Eminere 3/4</b> Cool White LEDs saturation control (0-100%)	proportional
-	-	7	-	0 - 255	<b>Warm White 4 -Eminere 4</b> Warm White LEDs saturation control (0-100%)	proportional
-	-	8	-	0 - 255	<b>Cool White 4 -Eminere 4</b> Cool White LEDs saturation control (0-100%)	proportional
-	-	-	1	0 - 255	<b>Dimmer 1</b> Light intensity coarse (0 - 100%)	proportional
-	-	-	2	0 - 255	<b>Dimmer Fine 1</b> Light intensity fine	proportional
-	-	-	3	0 - 255	<b>Dimmer 2</b> Light intensity coarse (0 - 100%)	proportional
-	-	-	4	0 - 255	<b>Dimmer Fine 2</b> Light intensity fine	proportional
-	-	-	5	0 - 255	<b>Dimmer 3</b> Light intensity coarse (0 - 100%)	proportional
-	-	-	6	0 - 255	<b>Dimmer Fine 3</b> Light intensity fine	proportional
-	-	-	7	0 - 255	<b>Dimmer 4</b> Light intensity coarse (0 - 100%)	proportional
-	-	-	8	0 - 255	<b>Dimmer Fine 4</b> Light intensity fine	proportional
Copyright © 2022-2023 Robe Lighting s.r.o. - All rights reserved						
All Specifications subject to change without notice						